

Unical

TRIKOND.



A duo with high efficiency



Aluminium for condensation, inox for protection

The condenser is constituted by elements in aluminium casting; their disposition has been studied in order to obtain a smoke passage decreasing section, to obtain the maximum condensation coefficient.

The heat losses of these element assembled in parallel, reduces the water and smoke passages losses. The condenser is put into a box completely in inox, to reduce all the corrosion phenomena.

The lateral chimney connection reduces the equipment depth and make easier the connection to the chimney.

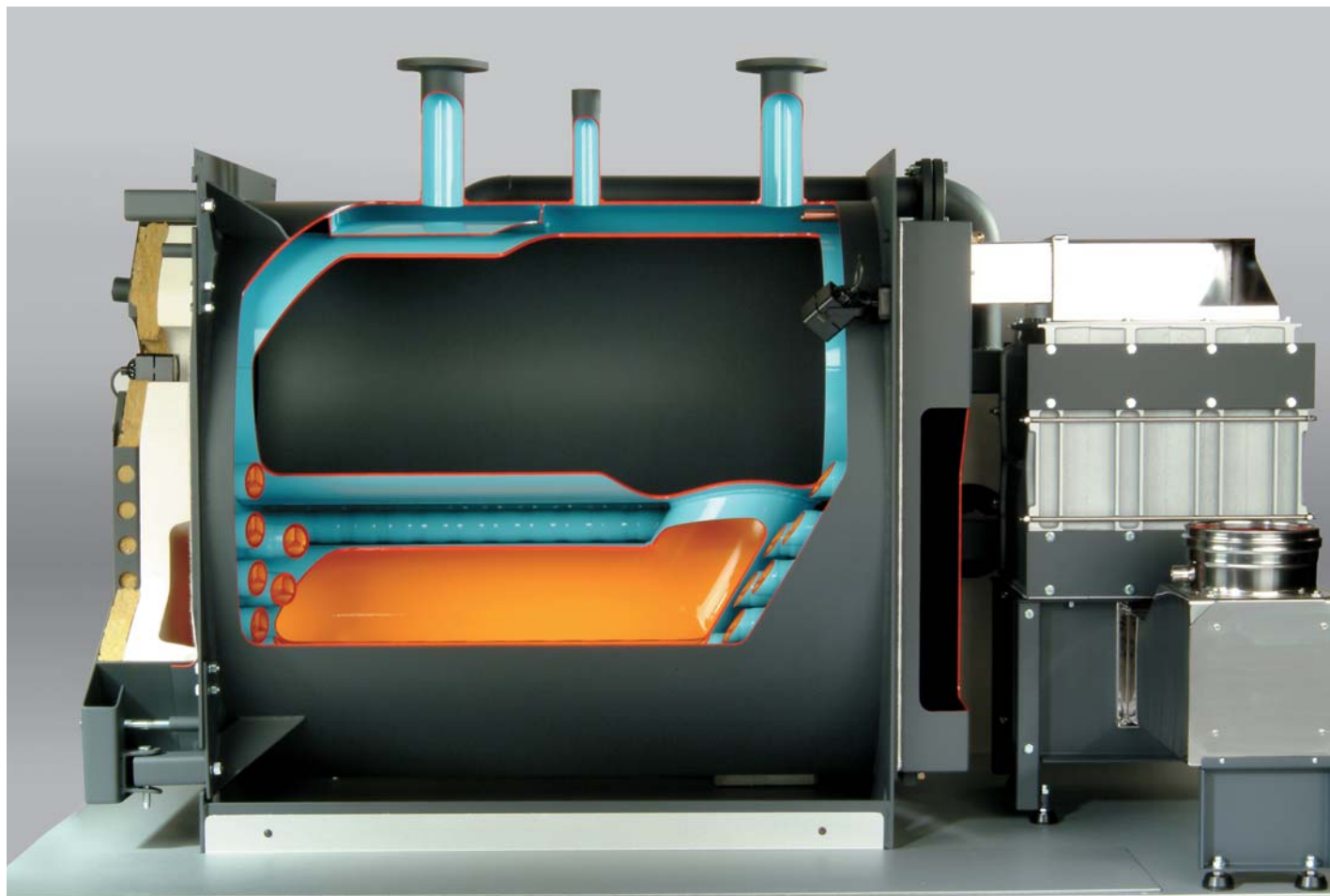

Trikond: new energy to the water

■ 3 SMOKE
PASSAGES BOILER

■ NATURAL GAS
PRESSURE JET
BURNER

■ ON/OFF OPERATION AT
LOW TEMPERATURE

■ CONDENSER WITH
ALUMINIUM ELEMENTS

■ AT HIGH
SEASONAL
EFFICIENCY

A perfect trio

TRIKOND is an unit composed by:

- natural gas pressure jet burner, complete with gas ramp and management / flame control devices
- 3 smoke passages steel boiler with open furnace at direct crossing and third smoke passage with special anti condensing pipes
- condenser with special aluminium casting elements, with pins studied in order to obtain the maximum smoke condensation degree.

Fines smokes geometry

A particular distributor manifold inside the boiler optimize the water circulation and favours a correct temperatures stratification, while the combustion gases driven circuit allows to exploit at the best the thermal exchange surfaces. The furnace at direct crossing (no more with reversed flame) reduces the combustion gases permanence in the high temperature zone; the burner flame results more compact and shorter, and with

provided for burners is possible to reduce the NOx emissions. The plated pipes are constituted by an external pipe at direct contact to the water, and inside by three pipes at sectors of 120°C each one. The necessary contact for the heating exchange is obtained by mechanical deformation of plating.

The combustion steel

The plating process creates thermal localized parts that control the heat exchange and reduce the conductivity increasing the medium temperature of exchanging surfaces. Is so possible the operation with low water temperature without condensation formation.



Technical data

DIMENSIONS

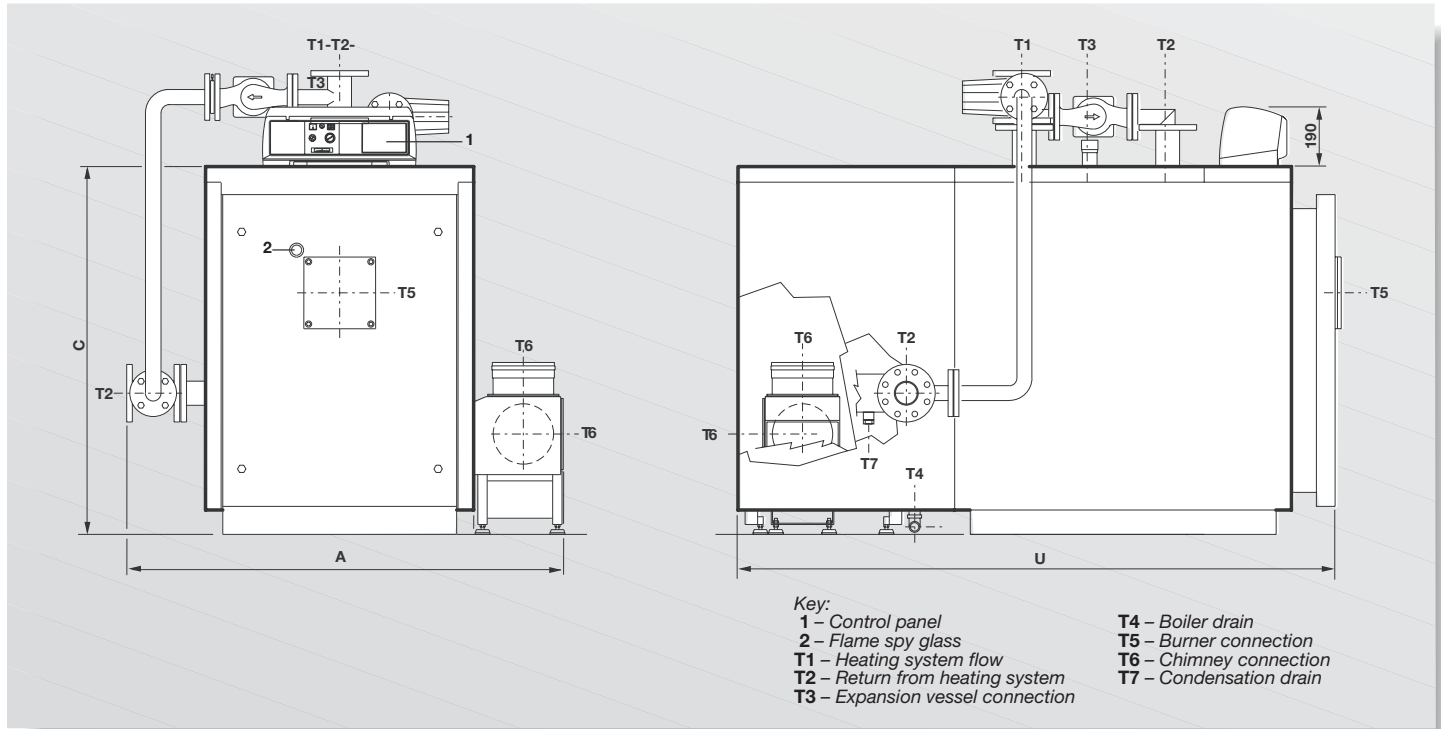

TECHNICAL DATA

TRIKOND		200	265	330	400	500	660	900	1100	1300
NOMINAL INPUT	kW	186,4	248	308	374	467	617	841	1028	1215
MINIMUM INPUT	kW	111,6	148,3	184,5	223,4	279,7	369,5	503,1	615,1	727,1
NOMINAL OUTPUT IN CONDENSING CONDITIONS (30/50°C)	kW	200	265	330	400	500	660	900	1100	1300
NOMINAL OUTPUT (60/80°C)	kW	182	242,6	302	367,3	459	606	826	1010	1193
FLUE GASES FLOW RATE WITH G20 (80/60°C)	kg/h	303,3	379,6	491,4	594,7	729	964	1351	1619	1888
MAXIMUM SMOKE TEMPERATURE (80/60°C)	°C	64	64	64	64	64	64	64	64	64
EFFICIENCY AT 100% LOAD IN CONDENSING CONDITIONS	%	107,3	107	107	107	107	107	107	107	107
EFFICIENCY AT 30% LOAD IN CONDENSING CONDITIONS	%	108	108,2	108,1	108,4	108,4	108,4	108,4	108,4	108,4
EFFICIENCY AT 100% LOAD IN STANDARD CONDITIONS	%	97,6	97,8	98	98,2	98,2	98,2	98,2	98,2	98,2
EFFICIENCY CATEGORY (92/42/CEE DIRECTIVE)		★★★★	★★★★	★★★★	★★★★	★★★★	★★★★	★★★★	★★★★	★★★★
CONDENSATION PRODUCTION	kg/h	17	18	22	26,5	35,5	49	73	85	104
MAXIMUM WORKING PRESSURE	bar	5	5	5	5	5	5	5	6	6
CO EMISSIONS WITH O ₂ = 0%	ppm	<35	<35	<35	<35	<35	<35	<35	<35	<35
WATER CONTENT	l	311	312	439	440	721	811	961	1621	1878
FLOW/RETURN CONNECTIONS	DN	65	65	80	80	100	100	100	150	150
EXPANSION VESSEL CONNECTION	ISO 7/1 DN	1 ½	1½	2	2	65	65	65	80	80
CHIMNEY CONNECTION	Øi mm	200	200	200	200	250	250	300	300	-
CONDENSATION DRAIN CONNECTION	Øi mm	40	40	40	40	40	40	40	40	40
VOLTAGE / FREQUENCY	V/Hz	230/50	230/50	230/50	230/50	230/50	230/50	230/50	230/50	230/50
DEPTH	mm	1914	2044	2264	2459	2604	2934	3440	3898	4268
HEIGHT	mm	1182	1182	1352	1352	1645	1645	1432	1542	1542
WIDTH	mm	1410	1410	1410	1410	1718	1718	1803	2156	2186
WEIGHT	kg	921	1034	1294	1463	1980	2275	2485	3568	3952
SMOKE RESISTANCE	daPa	22	33	35	45	42	60	85	95	98
WATER SIDE PRESSURE LOSSES (Δt 15K)	kPa	5	9	12	17	8	10	13	16	18
CO ₂ LEVEL	%	9,7	9,7	9,7	9,7	9,7	9,7	9,7	9,7	9,7

IMPORTANT: for the models TRIKOND 1100 and TRIKOND 1300, the connections T1 and T3 are reversed, and from the model TRIKOND 500 the connections are flanged.