

Unical

TERSEC.



Highest efficiencies with sliding temperature

The principal causes of atmospheric pollution caused by heating systems essentially depends on the type of fuel used and from the quality of the combustion and consequently also from the constructive characteristics of the boiler and the burner. These harmful substances, and in particular the nitrogen oxides classified under the NO_x formula, are responsible of the reactions and the chemical processes that produce the acid rains and the greenhouse effect.

Therefore, it is evident that all the reference Standards have the tendency to limit the emissions of harmful substances. The NO_x formation process is greatly influenced by:

- **The flame temperature**
- **The period of permanence of the combustion gases in the high temperature zone**
- **The oxygen's partial pressure and its concentration;**

Therefore, to be able to destroy the formation of NO_x it is indispensable to:

- reduce the combustion temperature;
- decrease the specific thermal load (kW/m³);
- reduce the time of permanence of the combustion gases in the furnace;
- reduce the oxygen's concentration.

The goal of lowering the NO_x has been reached with the boiler TRISECAL 3P, adopting the following constructive solutions:

- **smoke passage**
the furnace no longer works with flame inversion but, on the contrary, with direct passage; consequently the burner flame is more compact and shorter, thus reducing the time of permanence at high temperature; moreover, thanks to a correct hot gas routing, the flame can be cooled down by the furnace walls soaked with water.

- **reduction of the thermal load**
The volume of the combustion chamber has been increased in comparison to standard boilers of equal output. A further reduction of NO_x is obtained by using modern burners specially designed, so as to permit a reduction of the air excess.

The second goal that TERSEC has set itself is to guarantee seasonal efficiencies above the average thanks to the tested technologies that employ deep sliding temperature until the boilers shuts down without causing any damage to the boiler's structure.

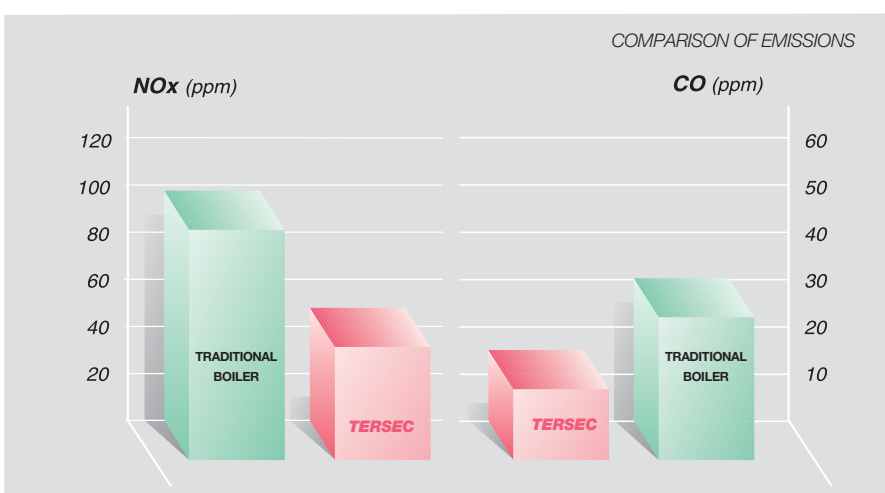
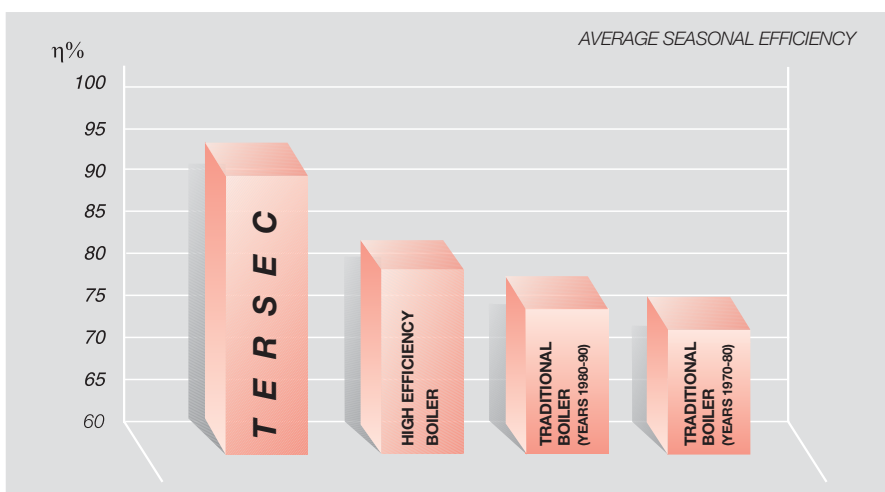

- *DIRECT CROSSING FURNACE WITH AN EFFECTIVE THREE SMOKE PASSAGE (> EFFICIENCY AND < NOX)*
- *FULLY ADJUSTABLE DOOR WITH DOUBLE OPENING (LEFT AND RIGHT) WITH CERAMIC FIBRE INSULATION (~30% RADIATION HEAT LOSSES)*
- *OVAL SHAPE SHELL DESIGN FOR SPACE SAVING INSTALLATION, UP TO 800 KW MODEL*
- *SPECIAL CONTROL PANELS WITH THERMOSTATIC OR ELECTRONIC CONTROLS, AVAILABLE ALSO FOR CASCADE MANAGEMENT*
- *TRIPLE SECTION ANTI-CONDENSING SMOKE PIPES AT CONTROLLED HEAT EXCHANGE (UNICAL PATENTED)*
- *REAR ANTI-CONDENSING TURBULATORS FOR OPTIMIZING THE HEAT EXCHANGE IN THE SMOKE PIPES, WITH FRONT REMOVAL*
- *DEEP SLIDING TEMPERATURE OPERATION DOWN TO 25°C ON THE RETURN CONNECTION AND TOTAL BOILER SHUTDOWN.*
- *FULL 100 MM THICK GLASS WOOL INSULATION*
- *HEAT EXCHANGE OPTIMIZATION BY MEANS OF THE DRIVEN WATER PASSAGE IN THE BOILER*
- *PATENTED FIN EFFECT ON THE WELDING SEAMS OF PIPES ONTO THE REAR TUBE PLATE*
- *INSULATED SMOKE CHAMBER WITH DOUBLE WALL FOR ACOUSTIC AND THERMAL LOSSES REDUCTION*
- *RECOMMENDED FOR INSTALLATION WITH MODULATING AND LOW NOX BURNERS*



TERSEC: *assurance of long service life*

Derived from the famous Trisecal, of which they represent the natural evolution, the boilers of the series TERSEC are essentially formed by an external oval shaped shell, inside which is placed the cylindrical furnace completely wet, in which the combustion gases complete their first passage, and the particular tube bundle used for the second and third pass of the flue gases themselves. A special internal manifold distributor, placed in correspondence to the return pipe, optimises the water circulation and favours a correct stratification of the temperature, whilst the guided passage of the combustion gases enables the boiler to exploit the most the heat exchange surfaces and to balance uniformly the stress placed on the components in relation to the type of structure fabricated.

The tube bundle of the third smoke pass is made with patented smoke pipes which consent sliding temperature operation and total boiler shutdown in order to obtain considerably higher average seasonal efficiency when compared to

traditional boilers or to constant temperature boilers.

When we talk about operating with sliding temperature we mean the ability of a boiler to work at very low operational temperatures, (down to 25°C on return connection) without causing the formation of condensate.

When the heat request varies the boiler adjusts itself and reduces the operating temperature, and this is particularly useful in obtaining good efficiency results in spring and autumn.

Furthermore, this feature permits the boiler to be completely inactivated during the periods of time when there is no demand for central heating, arriving as far as the “complete shutdown” of the boiler, and subsequently restarting the boiler with a new cycle, without the risk of condensing in the transitory starting-up periods.

These pipes are guaranteed anti-condensing even with very low water temperatures because the major part of the exchange surface in direct contact with water is maintained at a high temperature thanks to an air space which is created between two adjacent compressed zones of the external pipe, which maintains them constantly above the dew point (refer to description in the specific paragraph). Hence, the tube bundle has been placed in the inferior part of the boiler where the water is at a lower temperature, in this way accomplishing an absolutely effective anti-condensing system without the need to install recycling pumps in order to avoid this type of problem.



The TERSEC DUO is, instead, a generator with two independent furnaces, controlled by a single control panel unit, with the possibility of cascade operation.

3 effective smoke passages

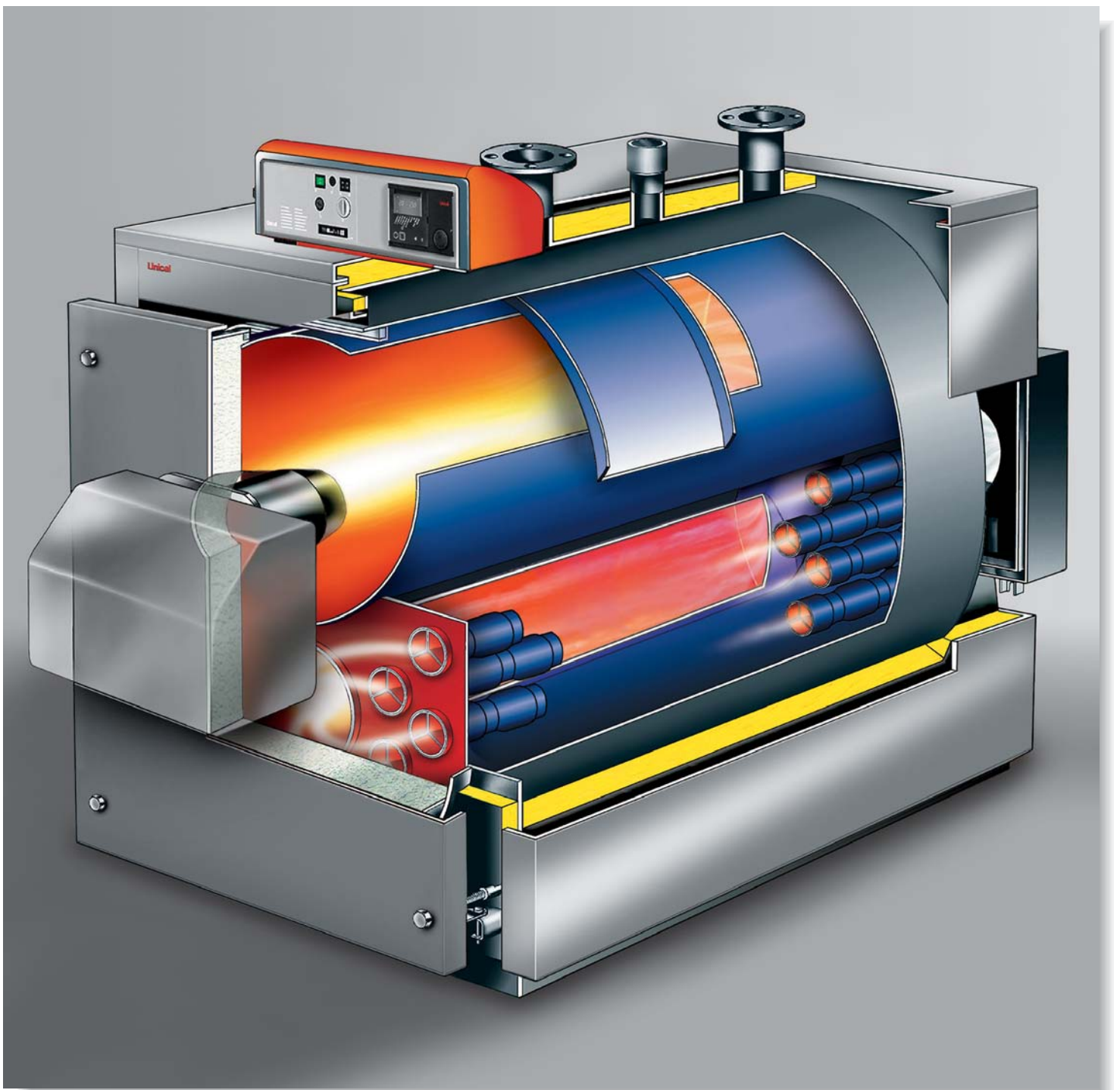

“Trisecal” pipes: an anti-condensing patent

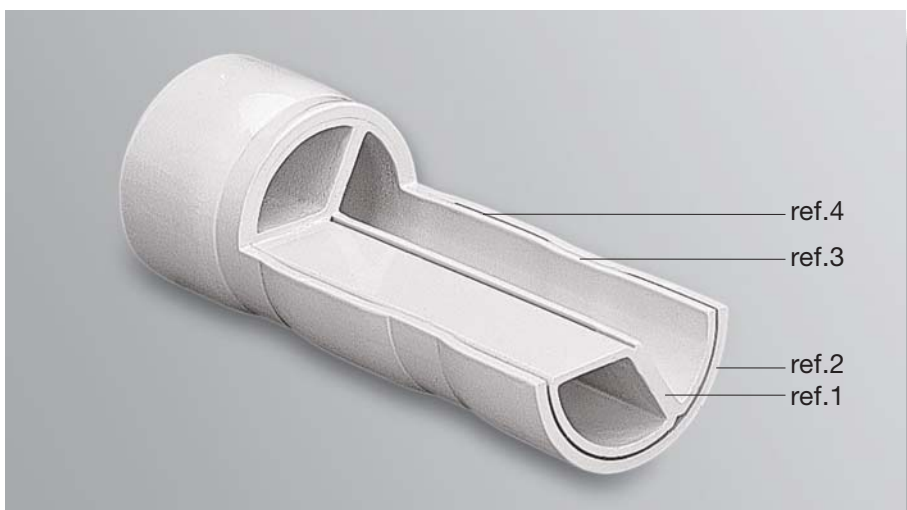

Tubo blindato a conduzione frenata (sez.)

The new triple section anti-condensing smoke pipe.

These are formed by a double pipe (ref. 2) in direct contact with water, inside which there are three tubes placed at a section of 120° (ref. 1). To bring about the heat exchange between the four tubes the necessary contact is obtained through mechanical deformation of plating with fixed distance. This plating creates thermal localized links (ref. 3) which regulate the passage of heat from the inside to the outside provoking a general rise in temperature of the internal profiles in contact with the combustion products. Between two adjoining platings the internal tubes remain separated from the external tube by means of an air space which, due to its low thermal conductivity, slows down the exchange in that area (ref. 4).

The TERSEC pipes represent the most currently efficient system for creating heat exchange with the maximum efficiency at all temperatures and without setting off any flue condensation.

SISTEMA BREVETTATO

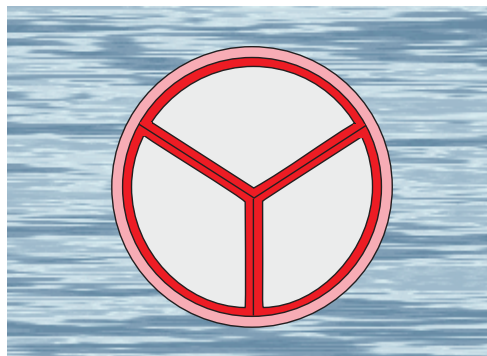

ZONA BLINDATA CON PONTE TERMICO

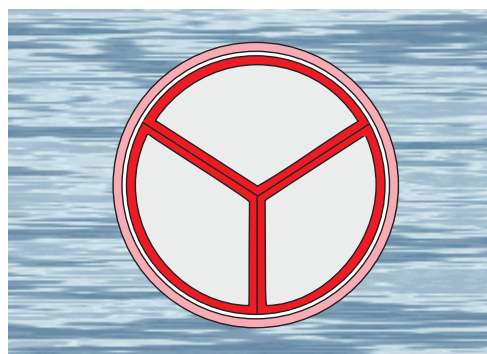

ZONA CON INTERCAPEDINE D'ARIA

Quality in small details

The front door

Particular care has been taken in the development of the sealing system for the combustion gases with respect to the environment (front door).

In fact, even a minimum opening in a combustion chamber under slight pressure could provoke a gas leakage at high temperature towards the outside, a subsequent burning of the gasket and overheating of the same door, resulting in its probable permanent deformation with serious effects to the safety conditions.

Due to these reasons we have developed a door particularly resistant to mechanical stress but equally and completely adjustable so as to ensure that the gasket is always centered with respect to the closing ring, whilst a self-locking elastic system repositions the door on the same gasket compensating the hardening of the ceramic fibre cord caused by normal wear.

The door is equipped with a special internal lining in ceramic fibre with very strong insulation properties and low thermal inertia which, reducing the boiler's steady state time, gives an additional contribution in eliminating the condense formation during ignition as well as reducing the irradiation losses by 30% in comparison with conventional insulation material.

Insulation

In TERSEC boilers the insulation has been optimized in order to greatly reduce the leakages caused by dispersion to the advantage of efficiency at nominal load and seasonal average. Insulation is obtained by means of a 100 mm thick mineral wool mat, placed directly in contact with the boiler body and protected by an external casing formed by steel panels coated with atoxic epoxy polyester resin powder.

The rear smoke chambe

It is isolated with respect to other possible condensed surfaces as it has been equipped with a dry partition which separates the same smoke chamber from the wet walls. The rear wet tube plate is therefore never touched by the combustion products thus preventing the formation of condense even at low working temperatures.



A large range with a minimum installation space required

One of the goals pursued during the development of TERSEC boilers was to supply a valid solution to the problems of space which are frequently encountered when existent heating plants have to be modernized. In many cases the boilers have to be installed in rooms with little space and difficult access. The oval structure of TERSEC is developed in a vertical expansion, with the furnace positioned above the tube bundle, and for capacities up to 600 kW, the boilers can pass through doors 800 mm wide.

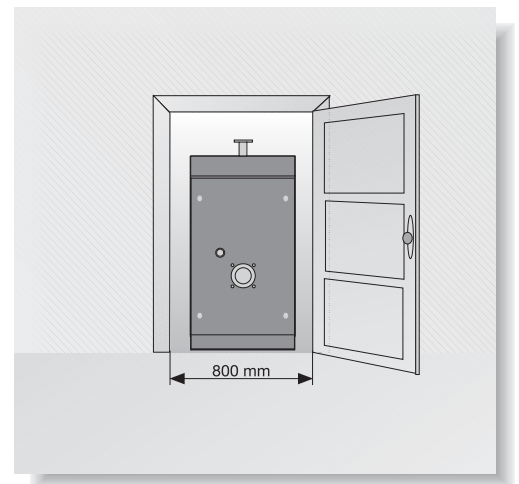

TERSEC S

For very narrow passages, is available TERSEC S (from 65 to 1000 kW), delivered in parts for assembling directly on the boiler room, keeping the same features of class and performances of the boilers manufactured in Unical factories. The approval with range of capacity allows to adjust TERSEC in order to gear it to every system, like a handmade dress!

DIMENSIONS IN WIDTH OF THE BOILER BODY WITHOUT THERMAL INSULATION (DIMENSIONS IN MM)

TRS 65	TRS 90	TRS 120	TRS 150	TRS 180	TRS 240	TRS 300	TRS 350	TRS 450	TRS 600	TRS 800	TRS 1000	TRS 1200
65 kW	90 kW	120 kW	150 kW	180 kW	240 kW	300 kW	350 kW	450 kW	600 kW	800 kW	1000 kW	1200 kW
660	660	710	710	750	750	780	780	790	790	1020	1360	1360

The control panel

The control panel has been developed in accordance with the current regulations and with the European Low Voltage Directive 73/23. On request, the control panel can be adapted to any configuration required by the heating system. The standard control panel is equipped with: the mains switch for the system pump and burner, boiler thermometer, a 2 stage working thermostat, a safety thermostat and minimum temperature thermostat. On request, we can supply a electrical control panel fitted with a digital thermoregulator with relative boiler sensors, return connection, outdoor sensors (standard equipment) and room sensors (optional) model type 20316.

TERSEC is supplied with a control panel model type 21059 which permits the adjustment of the burner, the pump and the water temperature.

For more complicated heating systems, electronic control panels with built-in thermoregulation (model type 21108) already installed and wired are available. These can control:

one direct zone C.H. system for without mixing valve, or a C.H. system for one zone with a motorized mixing valve, or two zone C.H. system: a direct one and one with a mixing valve (boiler sensor for an external storage tank and return connection supplied together with the boiler).

On request it is possible to run 2 boilers in cascade.

Thermoregulation

The main features:

Self-adapting program:

this function, which is obtained only if the room temperature sensor is installed, permits the generator to adapt its working functions to the building's characteristics by means of an elaboration of the data received from the same thermoregulation. This function is proof of a constant monitoring of the internal temperature varied by the change in the outside temperature, taking into consideration the building's thermal inertia and the "free" heat contributions (solar radiation, internal heat sources, etc).

Optimization:

the thermoregulation, on the basis of the hours set by the user, and once analyzed the heating system's features, will proceed with more or less anticipation, to start-up the boiler or change the state of the flame, in order to ensure the right comfort temperature at the hour requested by the user.

Overheating protection:

the control of the generator's safety temperature mode is ensured through the post-functioning of the circulators in order to dispose of any possible thermal inertia accumulated before shut-down in the furnace and in the flue pipes.

Exercise control of more than one zone:

with the same thermoregulation you can

control 2 independent circuits with different features, even though ensuring all the described functions.

Domestic hot water production:

there are many programmes which control the DHW production. One can choose from the maximum comfort to the maximum economy. In order to rapidly reach steady boiler operation the thermoregulation brings the boiler temperature to the maximum set value.

Anti bacteria function:

the boiler temperature is brought to 60°C every 20 heating cycles or at least once a week on Saturday at 1.00. With this procedure any possible pathogens which could originate in the DHW are eliminated.

Programme setting:

the hours can be set daily or weekly with various ignitions and shut-downs during the space of the day.

Note: The TERSEC DUO control panel is fitted with all the command and control instruments for both the boilers. The climatic thermoregulation board is fitted for cascade operation



Dimensions

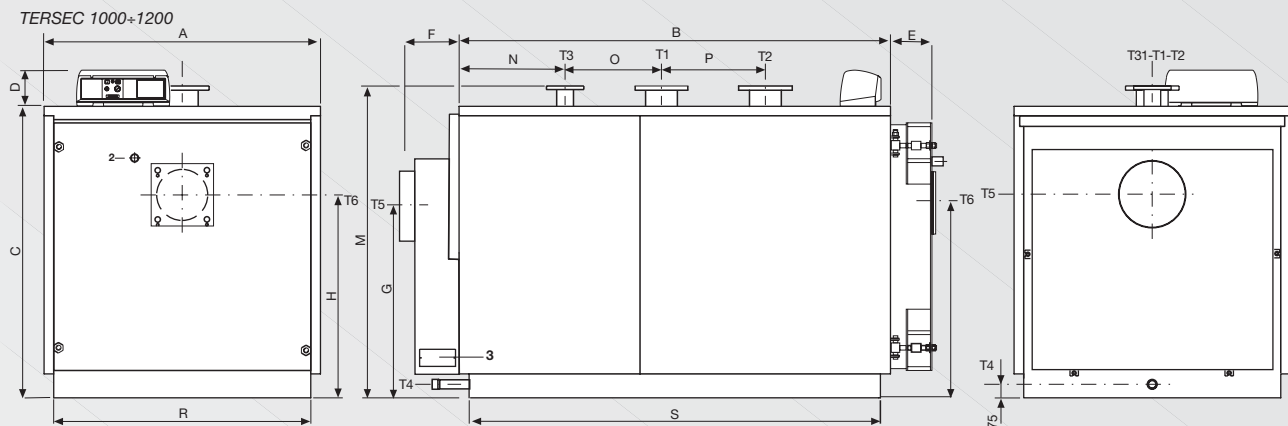
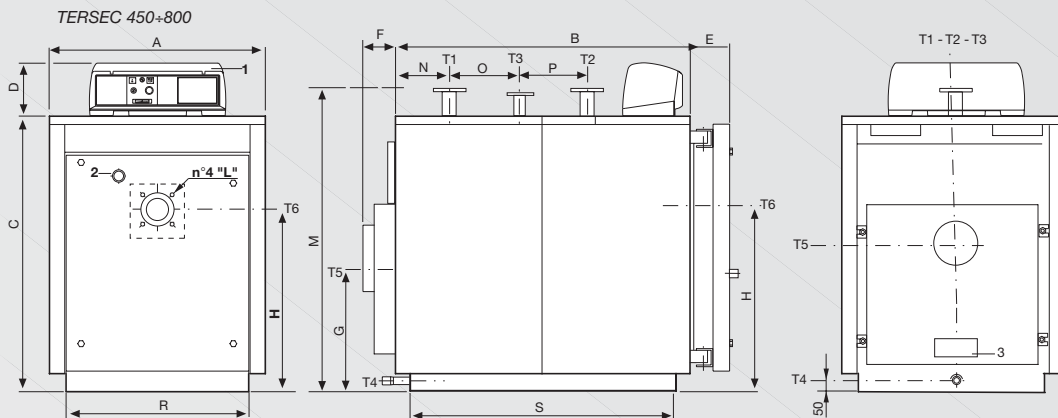
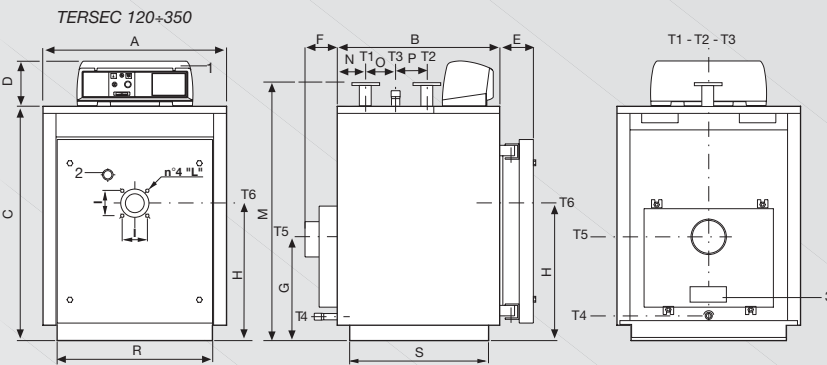
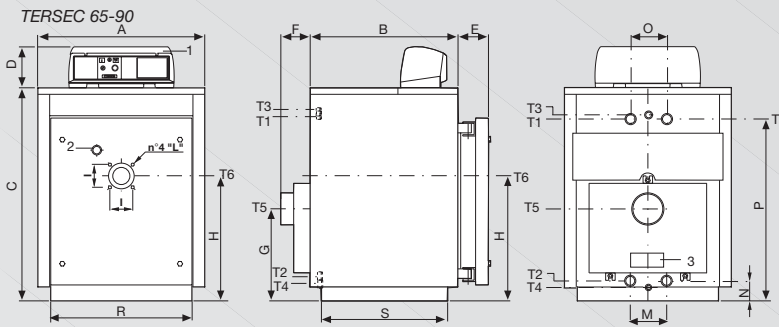

Delivery

TERSEC boilers are supplied with the jacket and the insulation packed separately, whilst the control panel and all the relative documents are placed, adequately protected, inside the furnace.

Into the instruction manual, supplied with the boiler, you can find all the sequences, even graphical, for a correct installation of all the parts.

The boiler can be cleaned easily thanks to the front port through which it is possible to reach any point of the combustion gas circuit.

The cleaning of the smoke pipes is carried out using appropriate pipe cleaners, supplied with the boiler, by first extracting the turbulators through the front plate with the provided for accessories.

- Key:
- 1 - Control panel
 - 2 - Flame spy glass
 - T1 - C.H. flow
 - T2 - C.H. return
 - T3 - Expansion vessel connection
 - T4 - Boiler drain
 - T5 - Chimney connection
 - T6 - Burner connection

Technical data

Model TERSEC	Output	Input	Water content <i>l</i>	Water side pressure losses (*) <i>w.c.m</i>	Flue side pressure losses <i>w.c. mm</i>	Net efficiency (with natural gas)		Maximum working pressure <i>bar</i>	Combustion chamber volume <i>m³</i>	Weight <i>kg</i>
	<i>kW</i>	<i>kW</i>				100%	30%			
TRS 65	50÷65	54,2÷71,1	132	0,04÷0,06	4,0÷6,5	91,4	92,5	5	0,059	326
TRS 90	70÷90	76÷98,4	188	0,05÷0,07	5,0÷7,5	91,5	92,5	5	0,087	398
TRS 120	90÷120	97,5÷131	201	0,06÷0,08	6,5÷11	91,6	92,5	5	0,103	486
TRS 150	120÷150	129,6÷163,5	266	0,08÷0,10	11÷17	91,7	92,5	5	0,139	575
TRS 180	150÷180	162÷196	289	0,11÷0,15	13÷19	91,8	92,5	5	0,155	626
TRS 240	180÷240	194÷261,2	320	0,14÷0,25	15,5÷27	91,9	92,4	5	0,176	739
TRS 300	240÷300	259÷326	413	0,14÷0,22	19÷30	92,0	92,4	5	0,239	949
TRS 350	300÷350	324÷380	479	0,22÷0,30	23÷31	92,1	92,4	5	0,280	1118
TRS 450	400÷450	430÷488	688	0,26÷0,44	29÷36	92,2	92,4	5	0,389	1545
TRS 600	500÷600	539÷650	770	0,25÷0,42	36÷52	92,3	92,3	5	0,443	1755
TRS 800	650÷800	700÷866,7	910	0,26÷0,44	37÷56	92,3	92,4	5	0,513	1885
TRS 1000	850÷1000	916÷1082	1552	0,26÷0,54	48÷66	92,4	92,4	6	0,680	2873
TRS 1200	1000÷1200	1075÷1298,7	1805	0,25÷0,64	48÷68	92,4	92,4	6	0,796	3257

TERSEC	A <i>mm</i>	B <i>mm</i>	C <i>mm</i>	D <i>mm</i>	E <i>mm</i>	F <i>mm</i>	G <i>mm</i>	H <i>mm</i>	I <i>mm</i>	L <i>mm</i>	M <i>mm</i>	N <i>mm</i>	O <i>mm</i>	P <i>mm</i>	R <i>mm</i>	S <i>mm</i>	Connections				
																	T1-T2 ISO7/1 UNI 2278 PN16	T3 ISO7/1 UNI 2278 PN16	T4 ISO7/1	T5 <i>Øi mm</i>	T6 <i>Øi mm</i>
TRS 65	740	690	950	190	140	145	437	585	120	M8	190	90	190	786	660	588	Rp 1 1/2"	Rp 1"	Rp 3/4"	150	130
TRS 90	740	950	950	190	140	145	437	585	120	M8	190	90	190	786	660	848	Rp 1 1/2"	Rp 1"	Rp 3/4"	150	130
TRS 120	820	885	1082	190	140	153	532	695	120	M8	1215	175	130	185	710	786	DN 50	Rp 1 1/4"	Rp 3/4"	180	130
TRS 150	820	1145	1082	190	140	153	532	695	120	M8	1215	175	390	185	710	1046	DN 50	Rp 1 1/4"	Rp 3/4"	180	130
TRS 180	860	1080	1182	190	140	153	757	775	200	M10	1315	215	210	250	750	981	DN 65	Rp 1 1/2"	Rp 3/4"	180	180
TRS 240	860	1210	1182	190	140	153	757	775	200	M10	1315	215	340	250	750	1111	DN 65	Rp 1 1/2"	Rp 3/4"	180	180
TRS 300	890	1275	1352	190	140	153	897	915	200	M10	1470	255	285	315	780	1177	DN 80	Rp 2"	Rp 3/4"	225	180
TRS 350	890	1470	1352	190	140	153	897	915	200	M10	1470	255	480	315	780	1372	DN 80	Rp 2"	Rp 3/4"	225	180
TRS 450	920	1605	1645	190	140	176	690	1130	-	-	1735	298	435	440	790	1504	DN 100	DN 65	Rp 1 1/4"	250	210
TRS 600	920	1800	1645	190	140	176	690	1130	-	-	1735	298	630	440	790	1699	DN 100	DN 65	Rp 1 1/4"	250	210
TRS 800	1122	2115	1432	190	195	195	790	960	-	-	1540	298	435	440	1020	2014	DN100	DN 65	Rp 1 1/4"	250	270
TRS 1000	1462	2282	1542	190	230	400	980	1035	-	-	1650	561	510	550	1360	2176	DN150	DN 80	Rp 1 1/2"	350	270
TRS 1200	1462	2652	1542	190	230	400	980	1035	-	-	1650	561	880	550	1360	2546	DN150	DN 80	Rp 1 1/2"	350	270

* Hydraulic resistance for delta T 15 K

Model	constituted by 2 boilers	Output	Input	Water content <i>l</i>	Water side pressure losses (*) <i>w.c.m</i>	Flue side pressure losses <i>w.c. mm</i>	Net efficiency (with natural gas)		Maximum working pressure <i>bar</i>	Combustion chamber volume <i>m³</i>	Weight <i>kg</i>
		<i>kW</i>	<i>kW</i>				100%	30%			
360	TRS 180	300÷360	324÷392	578	0,11÷0,15	13÷19	91,8	92,5	5	0,155 X 2	1252
480	TRS 240	360÷480	388÷522,4	640	0,14÷0,25	15,5÷27	91,9	92,4	5	0,176 X 2	1478
600	TRS 300	480÷600	518÷652	826	0,14÷0,22	19÷30	92,0	92,4	5	0,239 X 2	1898
700	TRS 350	600÷700	648÷760	958	0,22÷0,30	23÷31	92,1	92,4	5	0,280 X 2	2236
900	TRS 450	800÷900	860÷976	1376	0,26÷0,44	29÷36	92,2	92,4	5	0,389 X 2	3090
1200	TRS 600	1000÷1200	1078÷1300	1540	0,25÷0,42	36÷52	92,3	92,3	5	0,443 X 2	3510

* Hydraulic resistance for delta T 15 K

Model	constituted by 2 boilers	A <i>mm</i>	B <i>mm</i>	C <i>mm</i>	E <i>mm</i>	F <i>mm</i>	M <i>mm</i>	W <i>mm</i>	Z <i>mm</i>	Connections				
										T1-T2 UNI 2278 PN16	T3 UNI 2278 PN16	T4 ISO7/1	T5 <i>Øi mm</i>	T6 <i>Øi mm</i>
360	TRS 180	1730	1080	1182	140	153	1470	870	1373	DN 65	Rp 1 1/2"	Rp 3/4"	180	180
480	TRS 240	1730	1210	1182	140	153	1735	870	1503	DN 65	Rp 1 1/2"	Rp 3/4"	180	180
600	TRS 300	1790	1275	1352	140	153	1735	900	1568	DN 80	Rp 2"	Rp 3/4"	225	180
700	TRS 350	1790	1470	1352	140	153	960	900	1764	DN 80	Rp 2"	Rp 3/4"	225	180
900	TRS 450	1850	1605	1645	140	176	1650	930	1921	DN 100	Rp 65	Rp 3/4"	250	210
1200	TRS 600	1850	1800	1645	140	176	1650	930	2116	DN 100	Rp 65	Rp 1 1/4"	250	210

For the dimensions not quoted on the drawing of the TERSEC DUO please refer to the corresponding dimensions of each singular boiler

Unical

