

Dimensions and technical data

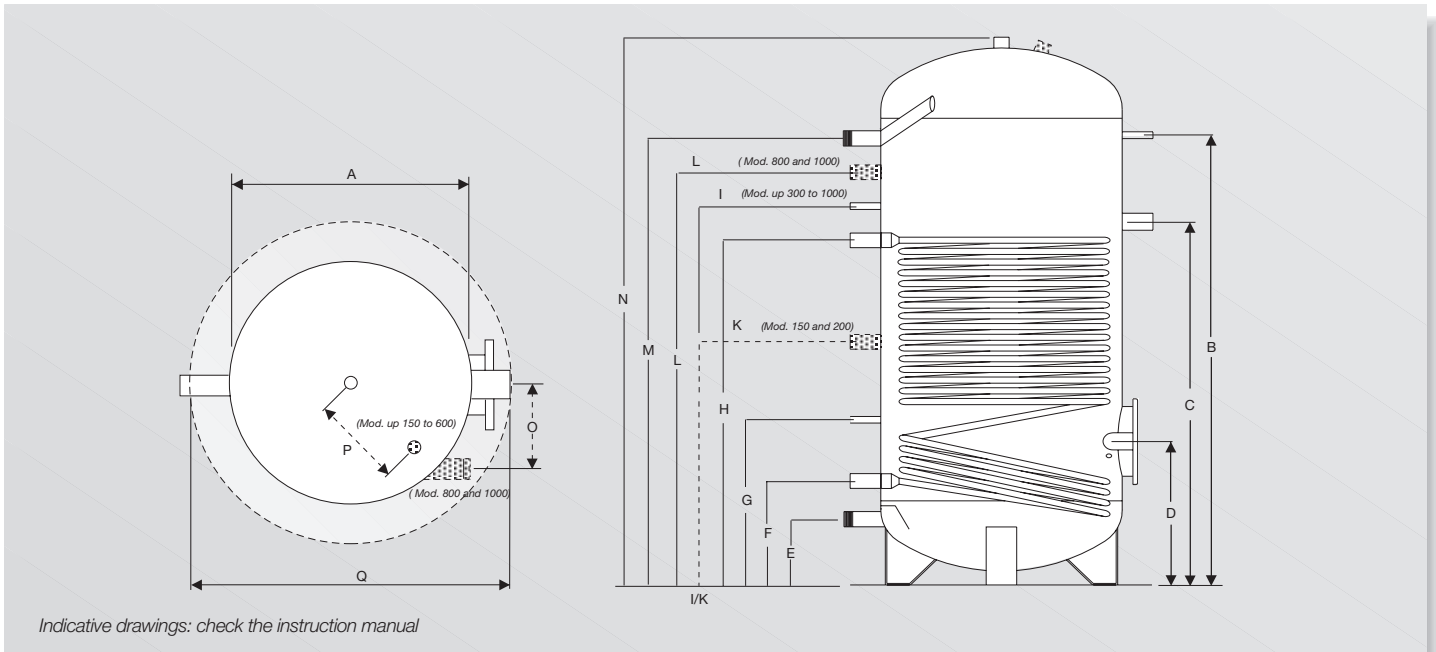

Models		150	200	300	400	500	600	800	1000	
DIMENSIONS:	A	mm	500	500	500	650	650	650	790	790
	B	mm	775	1005	1390	1195	1425	1695	1465	1720
	C	mm	655	810	955	835	960	1065	1135	1350
	D	mm	330	320	320	365	365	365	435	440
	E	mm	220	220	220	265	265	265	210	210
	F	mm	300	290	290	345	345	345	345	350
	G	mm	385	375	375	440	440	440	560	555
	H	mm	620	750	890	795	880	985	1035	1235
	I	mm	-	-	1165	960	1170	1340	1145	1395
	K	mm	495	635	-	-	-	-	-	-
	L	mm	-	-	-	-	-	-	1275	1535
	M	mm	765	975	1390	1185	1415	1685	1435	1700
N	mm	990	1215	1615	1460	1690	1960	1780	2030	
O	mm	-	-	-	-	-	-	200	200	
P	mm	150	150	150	150	150	150	-	-	
Q	mm	600	600	600	750	750	750	990	990	

Models		150	200	300	400	500	600	800	1000
Total capacity	l	168	212	291	423	500	589	765	888
Insulation in rigid injected PU.	mm	50	50	50	50	50	50	-	-
Insulation in flexible injected PU.	mm	-	-	-	-	-	-	100	100
Diameter of tank with insulation of 50 mm of injected PU	mm	600	600	600	750	750	750	-	-
Diameter of tank with insulation of 100 mm of flexible PU	mm	-	-	-	-	-	-	990	990
Power absorbed	kW	24	36	44	46	55	63	68	88
Flow rate necessary to the heat exchanger	m ³ /h	1,0	1,6	1,9	2,0	2,4	2,7	2,9	3,8
Production of D.H.W. $\Delta t = 25 K$ (cold water inlet at 15°C - hot water outlet at 40°C)	l/h	780	1170	1430	1430	1820	1950	2210	2730
Pressure losses	mbar	12	40	70	80	131	192	240	518
Flange	ø mm	180/120	180/120	180/120	180/120	180/120	180/120	180/120	180/120
Weight (empty)	kg	70	90	115	140	155	190	215	245
Maximum working pressure in the sanitary water side	bar	10	10	10	10	10	10	10	10
Maximum working pressure in the coil side	bar	6	6	6	6	6	6	6	6
Maximum temperature in the sanitary water side	°C	95	95	95	95	95	95	95	95

Unical

SANICAL.



SANICAL SC, the accumulation

The strong points of SANICAL:

- *Adaptability to all installations, thanks to the wide range*
- *High performance, thanks to the new elliptic heat exchanger coil, that permits speed of accumulation with an abundant and continuous drawing*
- *internal enamelling that guarantees an absolute hygiene and a long duration without corrosion.*



The range of SANICAL SC storage tanks for sanitary hot water is constituted by 8 models, from 150 to 1000 litres of capacity, for an absorbed output from 24 to 88 kW.

They are especially indicated to satisfy important drawings in a short time as, for example, schools, sporty facilities, hospitals, public offices, hotels, apartment houses. Thanks to the compact dimensions and to the wide exchange surface, they guarantee an optimum utilisation convenience ratio.

Pure hot water in economy

The SANICAL SC storage tanks are constructed of carbon steel and have an internal treatment of two layer enamelling.

The vertical cylindrical shape makes easy the phenomenon of the hot water stratification, while increasing the volume of useful drawing.

The helicoidal exchanger coil, placed inside, presents an elliptic new shape, that guarantees a more important exchange surface.

The high performances during preparation and hot water drawing, are, therefore, assured, even while exploiting a lower output.

IN OTHER WORDS, HOT WATER, WITH A LESSER ENERGY CONSUMPTION!

**5 years
guarantee**

For the high quality of its components and the care in the manufacturing phases the SANICAL SC storage tanks are guaranteed 5 years against all manufacturing defects, provided that the maintenance norms indicated in the instruction manual are respected.

Convenient solutions for stringent demands

A wide choice, a lot of solution

The wide choice of the SANICAL SC range permits to solve all types of demand, from the most reduced, with 150 litres, to the most demanding, with 1000 litres of storage of D.H.W. Besides, the possibility of mating with all models of UNICAL boilers guarantees the maximum flexibility of design.

The solar energy with SANICAL

The series of SANICAL SC storage tanks can be coupled directly to a thermal solar system, without the integration of a boiler: one more possibility to exploit the qualities of SANICAL SC in all types of installation.

Reduced heat losses: lesser fuel consumptions

The thermal insulation is made of rigid polyurethane of 50 mm for the models until 600 and in flexible polyurethane of 100 mm for the models 800 and 1000 litres. This solution guarantees a high protection against the heat losses, while reducing the decrease of temperature, of the stocked water and, therefore, the demands of the installation. IN SYNTHESIS: WATER ALWAYS HOT, WHILE RESPECTING THE ENVIRONMENT.

The ideal regulation

On all the storage tanks an optional regulation kit, that includes the panel board and the bulb holder, can be fitted. The control panel is equipped with:

- *ON / OFF switch*
- *regulating priority thermostat, which controls the tank loading pump*
- *thermometer*

Three regulation kits are available according to the capacity of the storage tanks:

1 kit for SANICAL SC 150, 800 and 1000

1 kit for SANICAL SC 200

1 kit for SANICAL SC 300 to 600

STORAGE TANK TYPE	KIT CODE
SANICAL SC 150, 800, 1000	32910
SANICAL SC 200	32911
SANICAL SC 300 to 600	32912

Detail of the tank cover with the optional control panel



Detail of the helicoidal exchange coil

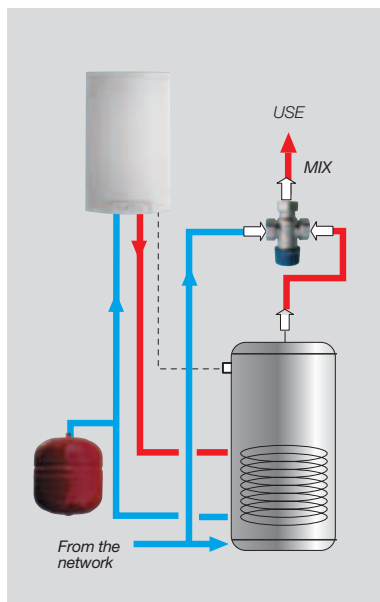

SANICAL SC in combination with a wall hung boiler

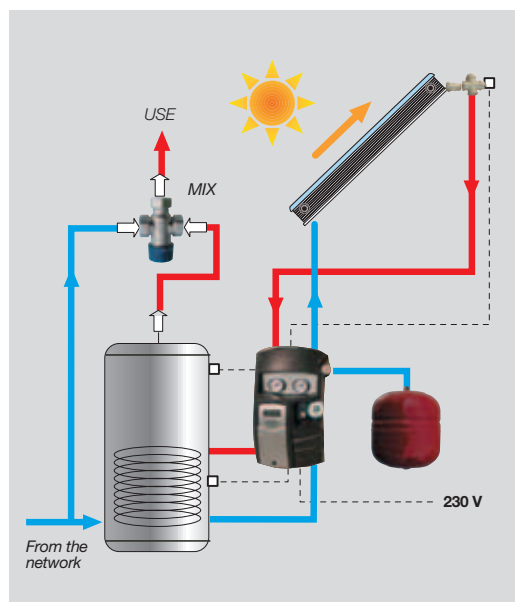

SANICAL SC in combination with a solar panel