

Unical®

INOXIA GJ.

HIGH WATER CONTENT STAINLESS STEEL
CONDENSING BOILER



INOXIA GJ
the winning choice



Discover the quality



MODELS	Nominal input (kW)	Nom. Output (condensing mode) (kW)	Pipe number	Effic.y (cond. mode) at 100% load %	Effic.y (cond. mode) at 30% load %	Condensate production (l/h)	Dimensions (L x P x H) mm
INOXIA GJ 150	140	150	54	107,1	109	20,9	956x1482x1645
INOXIA GJ 200	186	200	54	107,5	109	27,7	956x1482x1645
INOXIA GJ 270	253	270	80	107,1	109	37,7	1056x1733x1745
INOXIA GJ 350	327	350	80	107	109	48,8	1056x1733x1745
INOXIA GJ 450	420	450	126	107,1	109	62,7	1086x2143x1893
INOXIA GJ 600	560	600	126	107,1	109	83,6	1086x2143x1893
INOXIA GJ 800	746	800	168	107,2	109	111,3	1266x2468x2178
INOXIA GJ 1000	934	1000	168	107	109	139,4	1266x2468x2178

At the motto of the Dynamism

Rapid changes of the energetic scenery impose as many rapid answers.

Unical widens its range of condensing boilers and introduces the INOXIA GJ series.

A **high water content** condensing boiler for modulating burners pressure jet gas burners, completely in **stainless steel**.

INOXIA GJ finds application in all those cases in which, for specific installation reasons, it is necessary to use a high water content condensing boiler.

Its strength, its image

- 8 models from 150 to 1000 kW, operated on natural gas or LPG.
- Certified efficiency 109%.
- Very high quality of the materials and maximum resistance to the acidic condensates: entirely realized in stainless steel AISI 316L and AISI 304.
- Characteristic reversed L shape with high constructive technology.
- Simplified smoke way to reduce the pressure losses.
- Compact dimensions: it can easily pass through narrow spaces.
- Electronic panel board with E8 regulator for the management both of the loads and the burner.

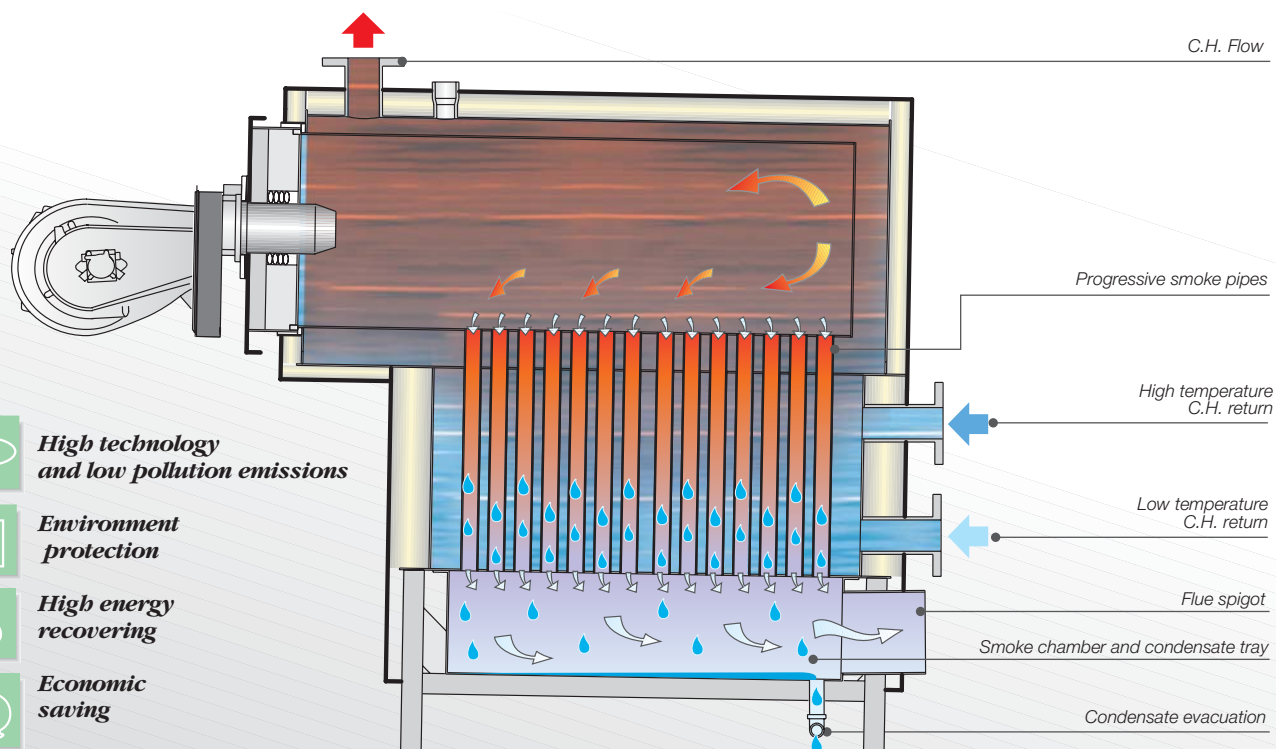

-  **High technology and low pollution emissions**
-  **Environment protection**
-  **High energy recovering**
-  **Economic saving**

INOXIA GJ

strong points

High quality of the employed metals

Boiler totally in stainless steel: combustion chamber in AISI 316 L, outer shells in AISI 304.

A detail of the combustion chamber completely water cooled and view of the underlying tube bundles.

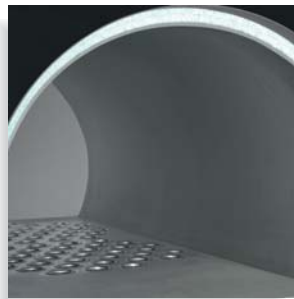

Maximization of the thermal heat exchange

Reversed "L" shaped structure. The assembly forms a simple structure countersigned by an initial horizontal part, where the flame produced by the burner develops. Through an entrance drawn on the bottom the smokes are diverted 90 degrees downwards.

Very high heat exchange vertical pipes Unical patent

Progressive vertical pipes in stainless steel AISI 316 L, armored externally and with aluminum fins internally.



Very high saving and seasonal efficiency

Thanks to the adoption of pressure jet burners with modulating ratio over 1:6 and the hydraulic circuit predisposed for two return connections (high/low temperature).

Certified efficiency of 109% at 30% load ★★★★★ CE

Self-cleaning of the tube bundle

Thanks to the natural washout that the condensate produces for gravity.



Simplified installation

- **Just one smokes evacuation connection** with the necessary manometric head for the evacuation of the smokes in every condition.
- **None hydraulic interface** between boiler and central heating installation.

Electronic expandable panel board

Panel boards equipped with electronic controller E8 expandable.

Predisposition for cascade operation

Up to 8 INOXIA GJ boilers controlled by the E8.



Wide range of regulation accessories

- **E8 controller** usable for the cascade management
- **Room sensor BMS**
- **Zone expander E8.1124**
- **Mixed zone flow sensor**
- **PT 1000 sensor** for management of solar collectors with E8

Thermal heat losses minimized

The INOXIA GJ boilers are acoustically and thermally insulated with a layer of 100 mm thick linen-faced rock wool.

Further more, the carbon steel door is insulated with biosoluble ecological fiber.



The quality in the details

Central heating flow connection flanged PN16

Door complete with flame sight

Adjustable with double opening (right or the left side).

Furnace in stainless steel AISI 316 L

Bimetallic vertical progressive pipes
Unical patent.

Door Isolation in biosoluble ecological fiber

30 reduction% of radiation heat losses.



Insulation 100 mm thick

Heat losses less than 0,5%.

Flanged HIGH temperature
return connection PN16

Flanged LOW temperature
return connection PN16

Boiler drain connection

Smokes chamber

In stainless steel, it carries to the chimney
the combustion products.

Condensate drain

It allows the complete evacuation of the condensate
produced by the combustion.

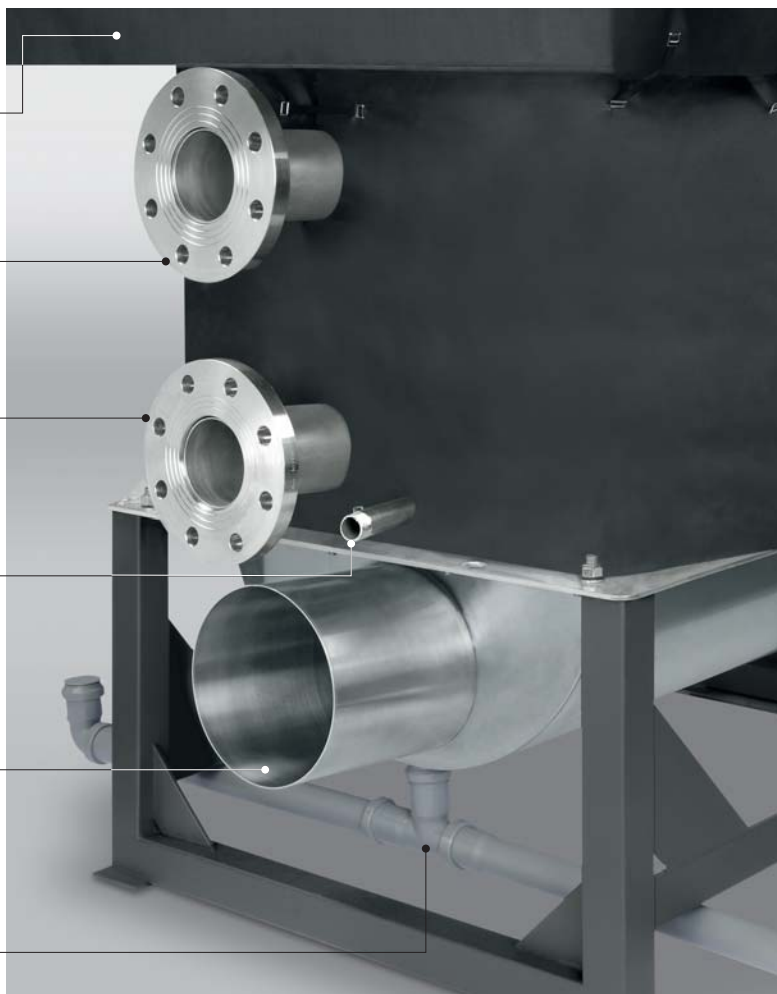

Smoke pipes progressive

Mechanical resistance and thermal efficiency

The INOXIA GJ series introduces particularities also from the hydrodynamic point of view, as *the driven and braked run of the water* inside the boiler, while the reduced counter-pressure of the smoke side guarantees a very silent operation and sufficient manometric head (1 Pascal, in combination with the most common burners) for an easy smoke evacuation.

A *special plate* conveniently perforated, placed between the furnace, where there is the smoke pipe entrance, and the underlying outer shell, develops the double important function of:

- so significant increase of thermal heat exchange of the pipes, avoiding hydraulic short circuits;
- significant increase of the mechanic resistance of the structure.

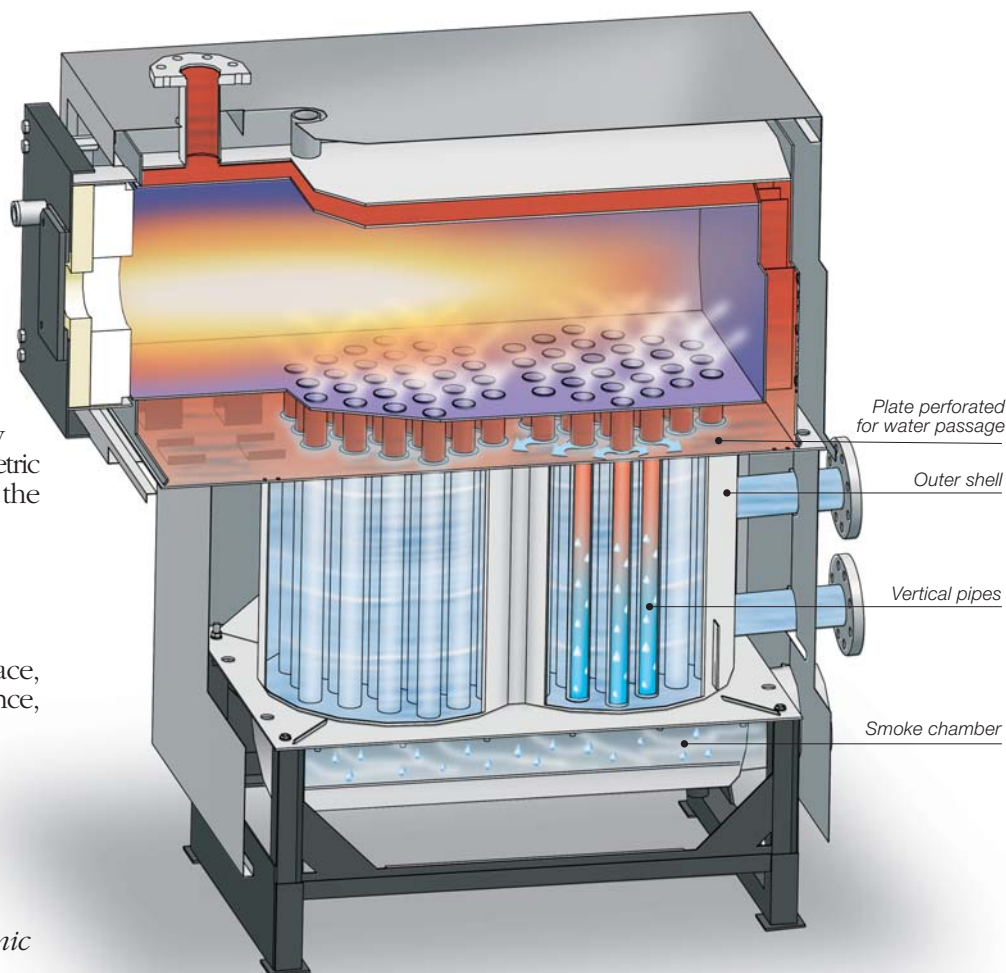

The smoke pipes, placed in 2 or more vertical tube bundles (depending on the output) favour:

- exceptional thermal heat exchange
- unctional evacuation of the condensate
- absence of wet acidic deposits
- elf-cleaning, for gravity, of the smooth exchange surfaces
- greater duration.

In fact, it is a question of stainless steel AISI 316 L circular pipes, containing, for all their length, a series of *multi-radial aluminium fins* which assure elevated heat exchange, withstanding the condensate.

The aluminum, with the same surface, maintains greater lightness, thus reducing the mechanical loads of the structure.

The two elements are armoured externally and assembled in just one block.

To favor the cold starts, the initial portion of the pipes has "progressive density" of the aluminum fins and convenient longitudinal length-breaker cuts.

The assembly **is patented** in order to guarantee the originality of the study.

The smoke temperature is indication of the quality of heat exchange of the tube bundle: in fact, at the entrance a smoke temperature of 750÷850°C is recorded. Only after 50 cm the temperature has gone down to 60°C.

Energetic efficiency reached objective

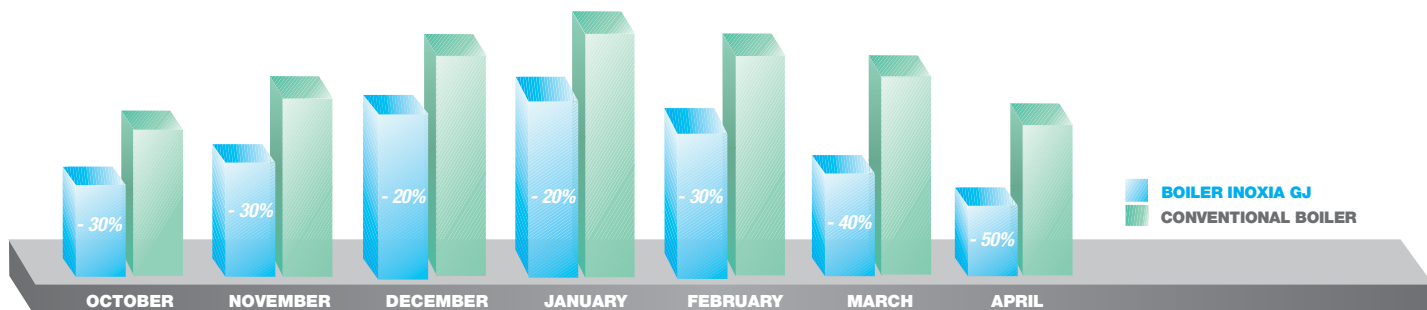

It is by now known to everybody that the advantages of the condensation, in comparison with the “conventional” combustion, allow improvements of the seasonal efficiency by **more than 30%**, thanks to the recovery of the latent heat in the combustion process.

The condensation systems represent:

- a sure positive budget for the energetic bill;
- a reduction of the polluting emissions.

Also the radiant systems working at high temperature (v. graphic below) thanks to the intervention of the E8 controller and to the direct connection to the return of the boiler, can work for very long periods below the “dew temperature” of the methane, thus provoking the phenomenon of the condensation that produces economic saving able to amortize the investment in a short time. The energy's need, therefore, is sensibly reduced, defining so a new more economic standard for the consumptions.

Smaller energy spent and greater comfort offered if compared with the conventional boilers.



COMPARISON BETWEEN THE NATURAL GAS BURNT WITH INOXIA GJ AND WITH A CONVENTIONAL BOILER

In the comparative diagram, a meaningful reduction is noticed of the consumption of natural gas with the boiler INOXIA GJ if compared with a conventional boiler, especially in the period of low thermal load (October, November, March, April, when INOXIA GJ shows its good abilities of adaptation to the more reduced load



HIGH TEMPERATURE SYSTEM REGULATION

The following graph represents the operation of a C.H. system at high temperature (design requirements: FLOW TEMPERATURE 75°C with Δt 15 e OUTER TEMPERATURE -5°C). With outer middle temperatures between +4 and +5°C (temperatures statistically more frequently detected in Italy in the winter period), the electronic system of the E8 controller plans a lower flow temperature (around 60°C) and, as a consequence, a RETURN TEMPERATURE below the “Dew point” (57°C) making the INOXIA GJ working in regime of condensation.

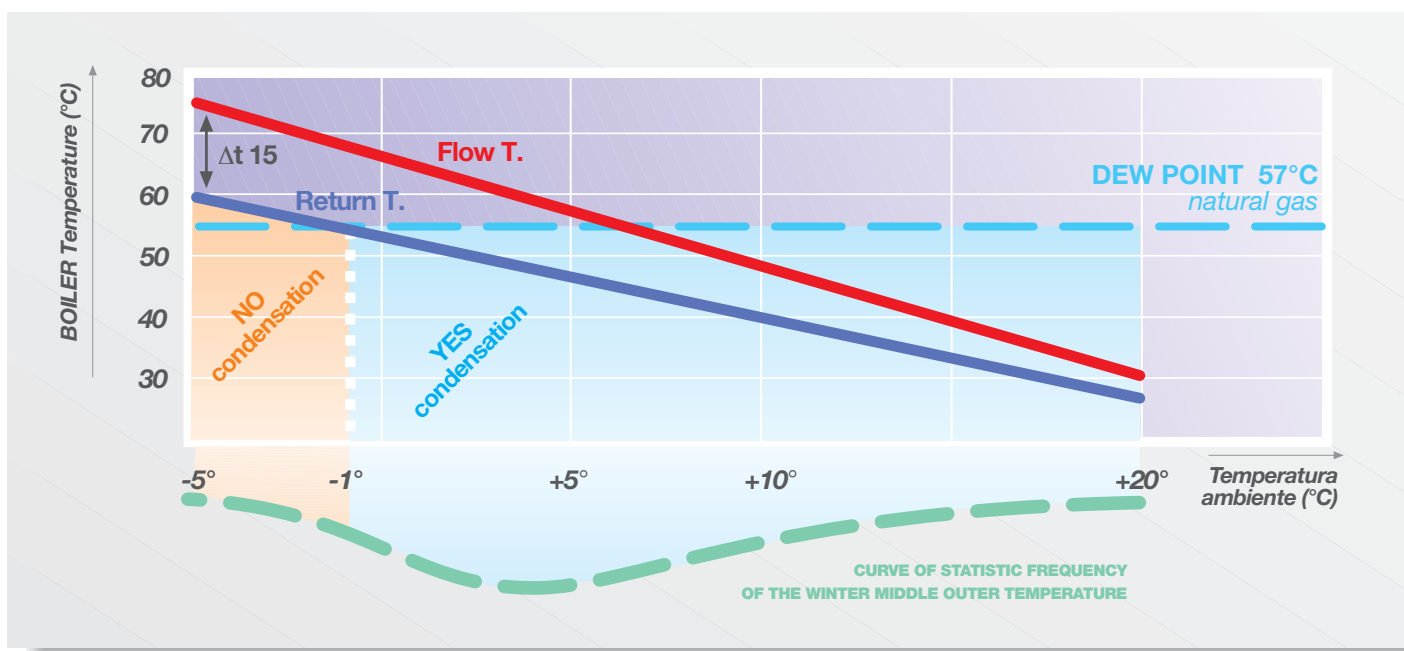

Power under control

Electronic panel board with E8 controller

It is not sufficient anymore having a very good, highly performing boiler. We know that the supplied output and temperature must be optimized according to the installation needs. The electronics of control has to offer an easy and flexible configuration.

- The electronic panel board, equipped with E8 controller, brilliantly resolves the, more and more often, complex demands of the users. Its temperature sensors, supplied as standard (boiler sensor, outer sensor, flow sensor and D.H.W. storage tank sensor) manage automatically the C.H. systems.
- The availability of the hourly and weekly programmer and the pre-setting of programs already planned, widens and facilitates the operations of customization.

Progressive and modulating two stage burners

In case of utilization of progressive or modulating two stage burner, endowed with interface RWF 40 and temperature sensor, it will be enough to connect it to the E8 controller, on the 0-10 volt/e-bus terminals, to get the data communication, able to synchronize the temperature/output request with the output supplied by the boiler. In this way the modulating capability of the burner and the condensing capability of the boiler are completely exploited, for the achievement **of the maximum energetic saving!**

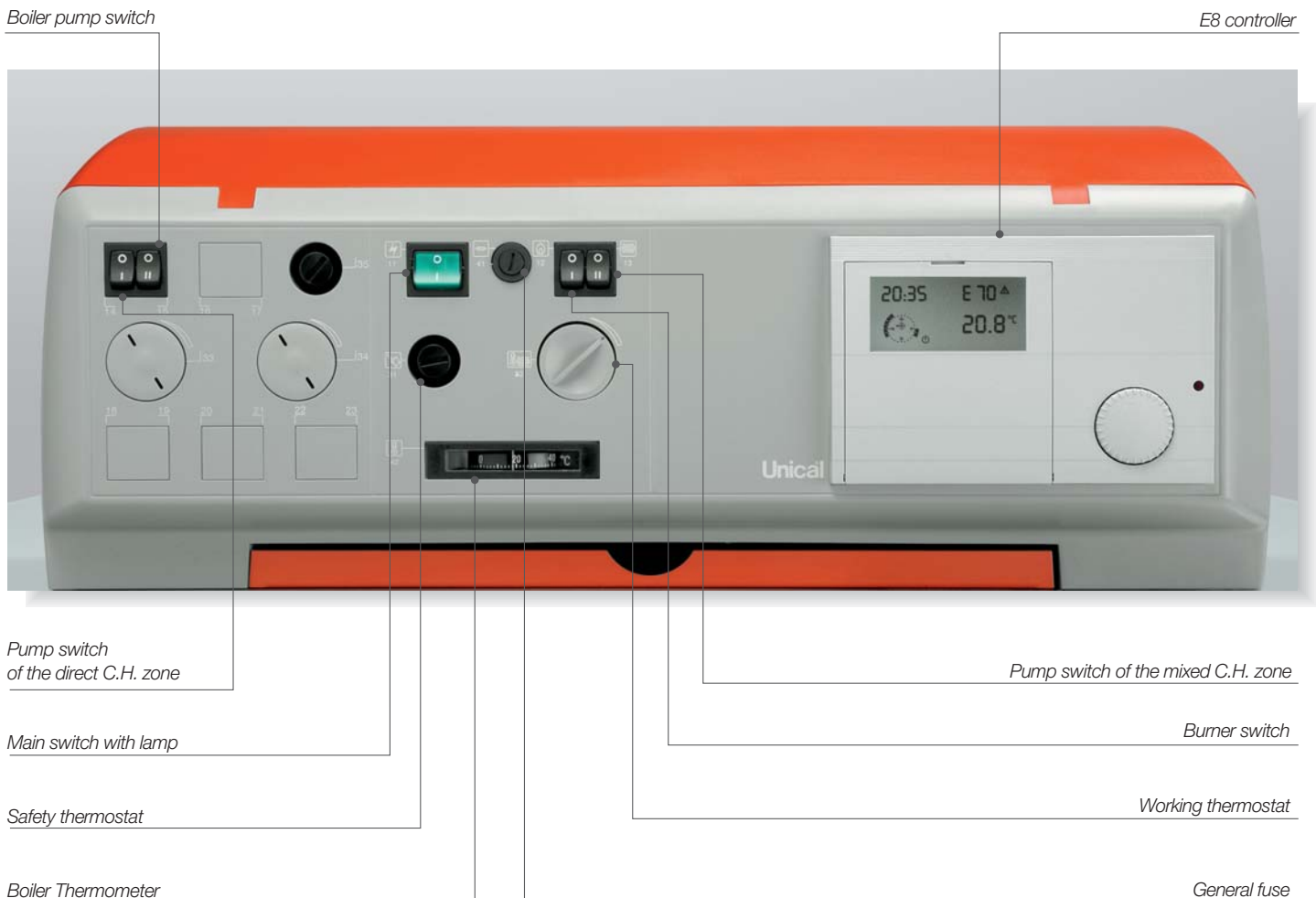

To program easily

E8, an intelligent controller

The application and the connection of the dedicated E8 controller, allows a decisive qualitative jump in the management of the boiler, depending on the applied loads.

E8, besides becoming the dialogue interface with the boiler, thanks to its prerogatives, allows the complete management of the C.H. system, exploiting the maximum output modulation and the maximum condensation attainable.



Function E8



Self-adaption

Through the elaboration of data transmitted by the room sensor, this function adjusts the boiler output to the building's characteristics, ensuring a constant monitoring of the indoor temperature on the basis of the variation of the outdoor temperature, keeping in consideration the building's thermal inertia and the contribution of "free" heat (solar radiation, internal heat sources etc).



Boiler heating Optimization

The heating controller, on the basis of the timer/heating programme set by the user, once the system's characteristics have been evaluated, will activate the function for automatically bringing forward the start of heating so as to ensure that the set temperature is reached at the time requested by the user.



Fast set temperature

This is obtained by calculating the optimum ignition start-up time. This calculation can be carried out taking into consideration the outdoor temperature or the room temperature.



Overheating protection

The boiler's safety temperature is controlled via the pumps overrun time in order to get rid of any thermal inertia.



Multiple zone control

With the same heating control you can control 2 independent circuits with different characteristics, though having ensured all the described functions, including the deep sliding temperature function.



Programme setting

The heating programmes can be set daily or weekly, with more than one On-Off firing times or temperature reductions during the arch of the day.



Domestic hot water production

There are many programmes which control the domestic hot water production. You can choose from the maximum of comfort to the maximum fuel saving. In order to permit the storage cylinder to supply hot water rapidly, the heating controller brings the boiler's temperature to the maximum set value.



Antilegion

Every 20 heating starts-up or once a week, on Saturday at 01:00 hrs, the storage tank is heated up to 60°C. This function will eliminate any eventual bacterium which have formed in the DHW.



Frost protection mode

The frost protection operation mode prevents the C.H. heating from freezing by automatically switching heating operation on. In the frost protection mode, the room temperature for all the heating circuits is set to 5°C and the storage tank sensor frost protection is activated when the temperature drops below 10°C.



Optimisation of DHW (loading pump)

The DHW loading pump is switched on only if the boiler temperature exceeds by 5K the storage tank temperature. It is deactivated when the boiler temperature drops below the storage tank temperature or if the storage tank temperature is higher than the nominal temperature.



Slope offset (heating slope distance)

The boiler temperature that is required for a

mixed circuit is calculated by adding to the calculated temperature setting for the heating circuit temperature the heating curve distance. The heating curve distance compensates for sensor tolerances and heat loss up to the mixer.



Number of burner ignitions



Burner run hours



Mixing valve opening time

Based on the characteristics of the servomotor

And more:

- **Management of up to 15 mixed circuits** controlled by the outdoor sensor (refer to accessories).
- **Integration with renewable energy sources** as for example: solar systems and/or solid fuel boilers.
- **0-10 volt signal:** the great flexibility of the E8 also permits the boiler set point to be controlled by an external control signal. This will enable, having at disposal an even more complex system, to exploit all the heating control's functions.
- **Remote controls*:** via appropriate software, this function enables the reduction of system management, remote indication of boiler run, thereby avoiding unnecessary inspection visits.

C.H. installations solutions



Installation with just one INOXIA GJ

The E8 controller will regulate:

- The working temperature of the boiler, depending on the outer temperature;
- The direct zone of the C.H. system, obviously also of floor heating type;
- The room temperature, that will be controlled and maintained through the selected heating curves;
- The C.H. system temperature, via the motorized mixing valve;
- The temperature and production of D.H.W. through the storage tank and the loading pump;
- The antilegionella function, by increasing the D.H.W. temperature at regular intervals.

Installation just with two INOXIA GJ

The panel board is always prearranged for the management of the two two-stage progressive or modulating burners according to the pre-set boiler temperature. With this system configuration the E8 controller will regulate:

- The direct zone of the C.H. system, obviously also of floor heating type;
- The room temperature, that will be controlled and maintained through the selected heating curves;
- The C.H. system temperature, via the motorized mixing valve and the flow temperature sensor, positioned down stream the mixing valve, which controls the pump and the mixing valve



Schematic diagram for C.H. SYSTEM with JUST ONE INOXIA GJ

Key

M - C.H. flow

Rbt - High temperature C.H. return

Rmt - Low temperature C.H. return

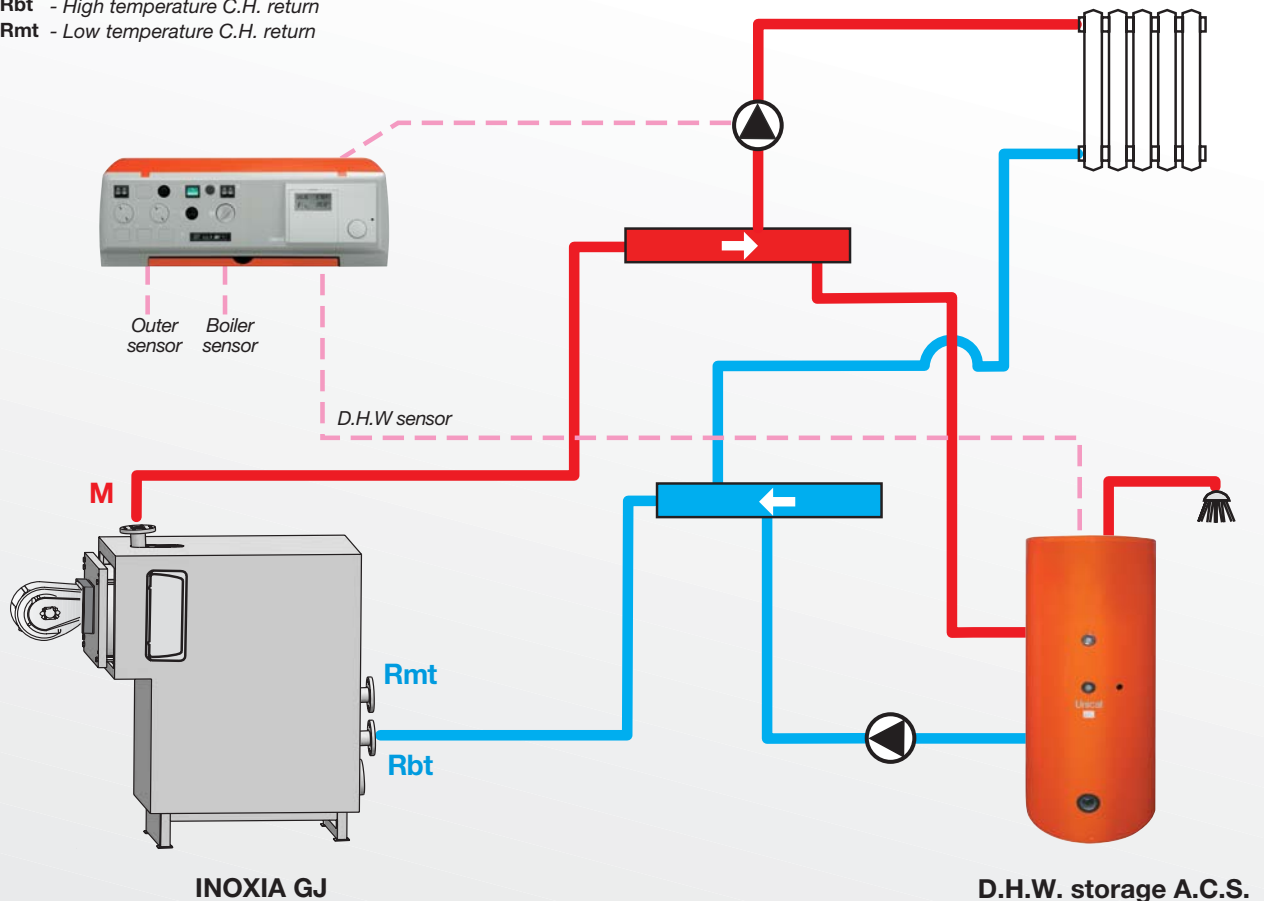



- *The temperature and production of D.H.W.* through the storage tank and the loading pump;
- *The antilegionella function*, by increasing the D.H.W. temperature at regular intervals.
- *The management of the central heating systems*, which is done automatically on the base of the data collected by the boiler, outer, room and flow temperature sensors;
- *Hourly and weekly programming* and pre-set programs;
- *Cascade operation* of the 2 boilers.

Naturally other solutions are available:
Go to the web site or contact our pre-sale office.

To complete and expand the controls on the C.H. system the following components are available:

- An additional E8 controller usable for the cascade management of two stage burners.
- Room temperature sensor BM8 that allows the temperature regulation in a specific place.
- Zones expander E8.1124 with which it is possible to manage 2 direct/mixed zones and a D.H.W. tank, up to a maximum of 7 modules.
- Mixed flow temperature sensor.
- PT 1000 sensor, for the management of solar collectors via E8.



Schematic diagram for C.H. SYSTEM just WITH TWO INOXIA GJ

Key:

- M** - C.H. flow
- Rbt** - High temperature C.H. return
- Rmt** - Low temperature C.H. return
- VF2** - 2nd zone flow temperature sensor
- VM2** - Zone mixing valve

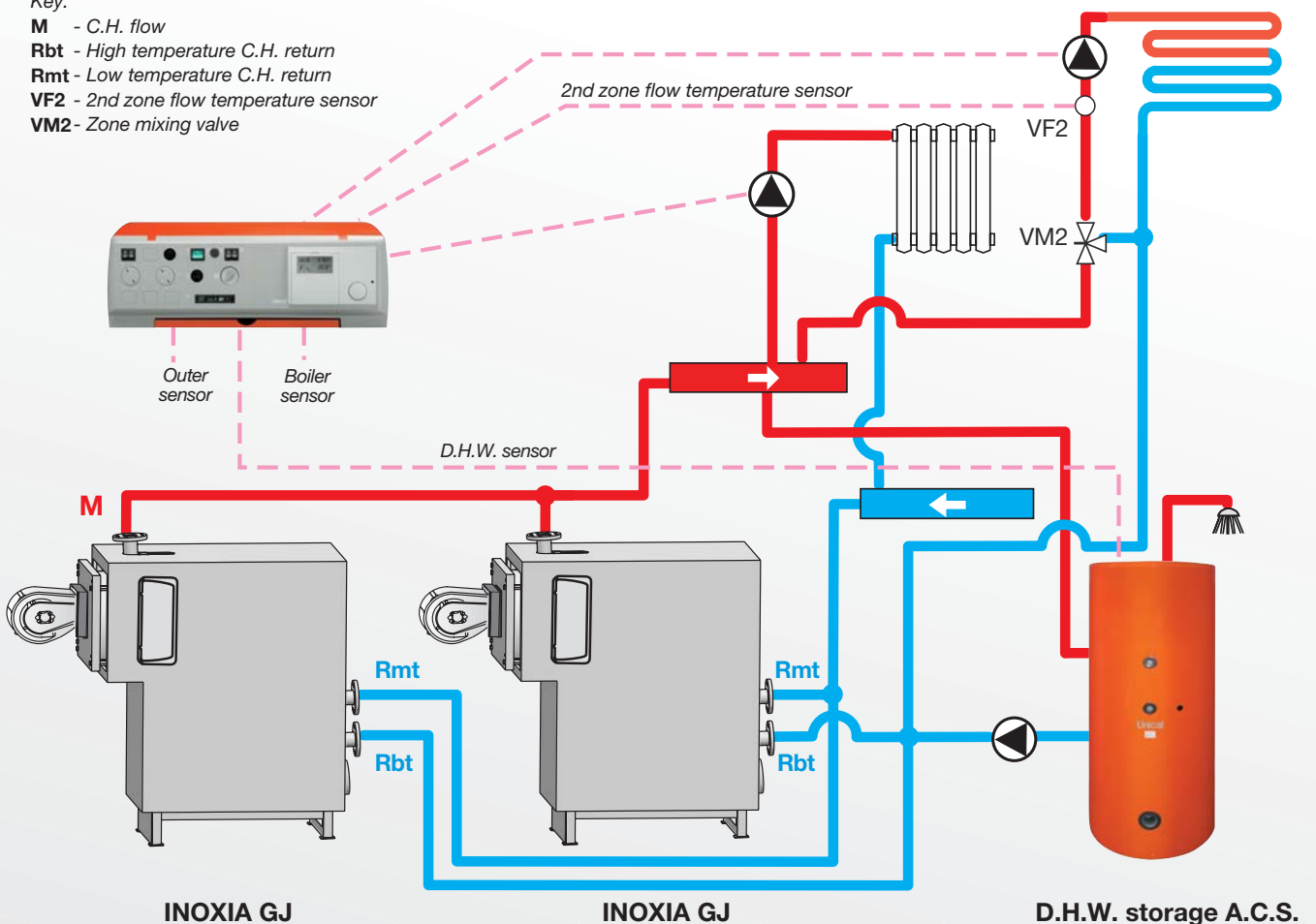

INOXIA GJ *and the sun*

INOXIA GJ and the renewable energies

The new installation requirements and the demand of consumers very sensitive to the environment protection bring to an increasing attention toward the renewable energies, first of all the solar one.

The outputs of INOXIA GJ allow to answer also to these demands: thanks to the E8 controller, combined with a PT1000 sensor (optional), is able, in fact, to manage any type of thermal solar installation.

Then, if the choice is the complete Unical packet, with the solar collectors TITANIUM and BLUETECH 2500 and the tanks BISER and SANRIS, the result is an optimized installation for the maximum exploitation of both, the clean solar energy and the condensation, getting, with just one solution, high efficiencies, saving and environment protection.



Schematic diagram

Key:

M - C.H. flow

Rbt - High temperature C.H. return

Rmt - Low temperature C.H. return

VF2 - 2nd zone flow temperature sensor

VM2 - Zone mixing valve

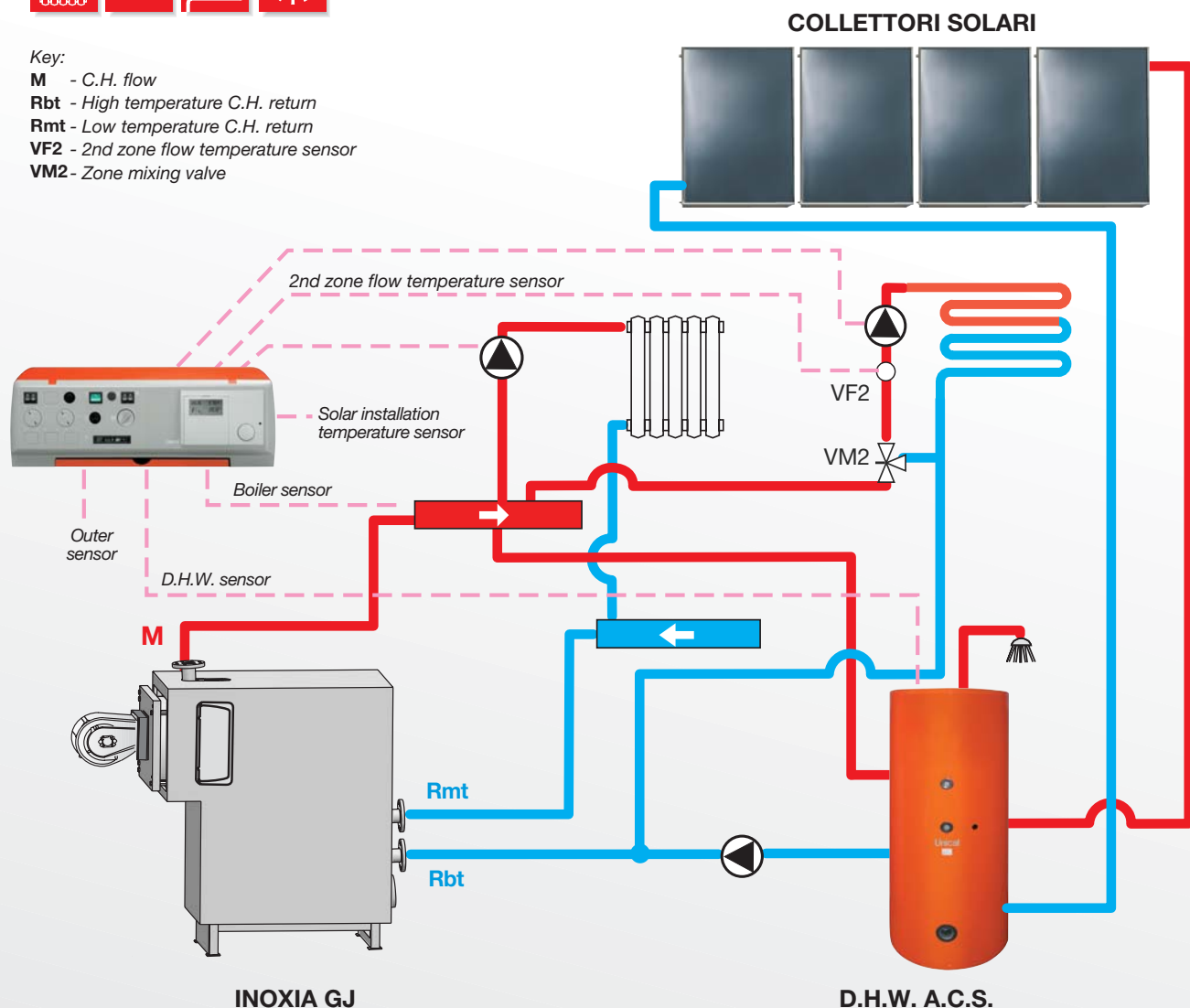

The new installation planning

The evolution of INOXIA GJ, has brought Unical, with the collaboration of the planners, the most sensitivo to the actual energetic problems, to develop and to realize projects, using INOXIA GJ in installations with high energetic saving.

The meeting point that today the market proposes to marry the demand of the consumer to have an individual management of the heating system and the one to have a centralized heating systems is represented by the zone satellites: when connected to the centralized boiler they allow the end user to have in his house the convenience of an autonomous boiler without flame.

Also in this type of projects INOXIA GJ knows how to answer to the demands in punctual and precise way.

If then the installation is realized with the Unical zone satellites, type SATAL, the heating system becomes "integrated", optimizing at the most the boiler efficiency, exploiting the logic of single regulation and entering in the books of every housing unit, and opening the road toward a global domotic control.

Naturally, other solutions are also available: go to the web site or contact our pre-sale service.

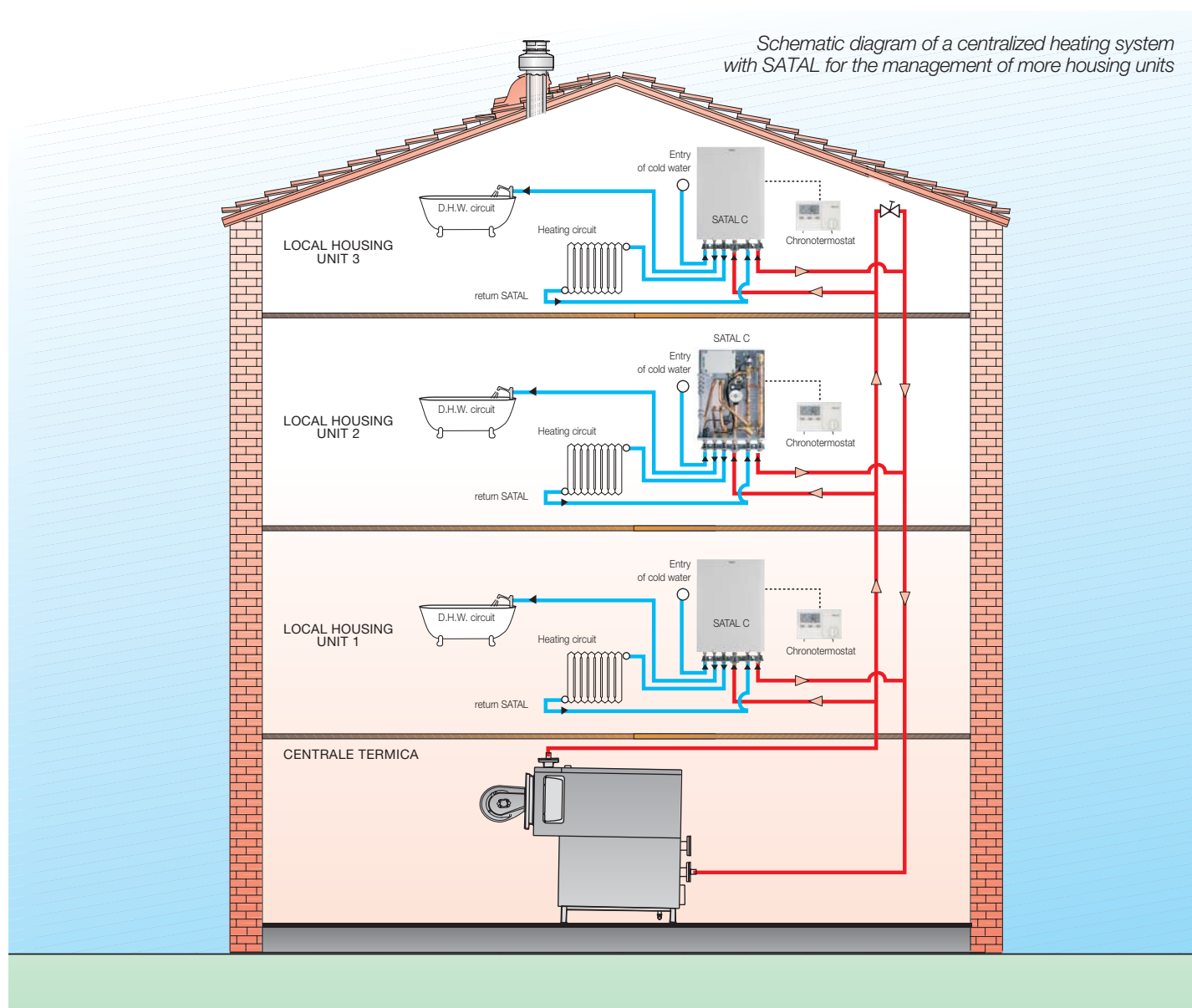

Installation and maintenance

Through every door

The INOXIA GJ are destined to C.H. installations for multifamily buildings, public buildings as schools and hospitals, and industries. It is obvious that the application of the condensation technique, also in the boiler substitution, will allow a consistent energy saving, therefore cost reduction. The introduction of the boiler in the boiler house won't be anymore a problem, thanks to INOXIA GJ. Up to the model of 600 kW, in fact, the naked boiler width (without casing) is only 790 mm, which allows the boiler to pass through a door of 800 mm and be introduced in the boiler house without performing any building works.

This is a notable advantage in the substitutions of old boilers!

Rapid assemblings

- Adjustable door with reversible opening (Right or Left Hand)
- Easy burner installation, thanks to the pre-drilled (on demand).
- Two bulb holders: every one can contain 3 sensors and thermostats bulbs.
- Accessories for the condensate drain

Simple maintenance

To preserve for a long time the very high thermal performances, the series INOXIA GJ has been designed for a facilitated, almost automatic maintenance:

- The wide door with reversible opening (R.H./L.H.) allows fast visual inspections for a rapid recognition of the state of the parts in contact with fire/smokes.
- The light inclination of the body, on the horizontal plan (around 2 degrees), toward the smokes evacuation, allows the carriage of the condensate and of the unburnts toward the tube bundle.
- The self-drainage of the stainless steel progressive pipes, thanks to the specularity of the metallic surfaces in contact with the smokes, provokes the entrainment of the unburnt particles toward the condensate drain and, from there, to the sewage.
- The quick removal of the casing panels, fitted by simple pressure and of the two elements of anallergic insulating fabric, allows to check the state of the whole stainless steel outer shell.

Accessories

Neutralizers (optional)

The condensate produced during the combustion process reacts with the NOx forming acidic molecules (pH = 4,5). It can become necessary the neutralization of such substances before the inlet in the sewage. In the respect of the ecosystem, Unical proposes the neutralizers of condensate NH.

Neutralizer NH 300

for boilers up to 300 kW (cod. 00262827): the neutralization happens according to the principle of the passage of the acidic condensate through the granular material of neutralization. The passage is from the lower part to the upper part.

Neutralizer NH 1500-P:

for boilers up to 1500 kW (cod. 00262829): in the neutralizer NH 1500-P the condensate is made to flow through a patented run in a zone filled by a neutralizing granular material, in which a filtering integrated layer is also found. At the exit from such zone the neutralized condensate reaches a pump with level control, acting also as lifting system, that pumps it toward the drain connection. Such neutralizer is able to treat up to 550 l/h of condensate, for boilers up to 1500 kW.

		NH 300	NH 1500-P
MAXIMUM FLOW RATE	l/h	70	550
MAXIMUM BOILER	kW	300	1500
OUTPUT MANOMETRIC	m	-	3
HEAD	mm	95	90
NEUTRALIZING MATERIAL		Calcium Carbonate	Calcium Carbonate
DURATION OF THE NEUTRALIZING MATERIAL		12 months (1500 working h.)	12 months (1500 working h.)
DIMENSIONS (L x W x H)	mm	410x310x220	670X470X280
INLET/OUTLET CONNECTION	mm	25	25 / 10
INLET/OUTLET HEIGHT	mm	30/100	30
OVERFLOW HEIGHT	mm	-	100
ELECTRICAL CONNECTION		-	230V/50Hz
ABSORBED ELECTRIC POWER	W	-	74
ABSORBED CURRENT	A	-	0,33
TYPE OF ELECTRICAL PROTECTION		-	IP 54

Recharge: NEUTRALIZING MATERIAL 25 kg; Refill NH

Dimensions and technical data

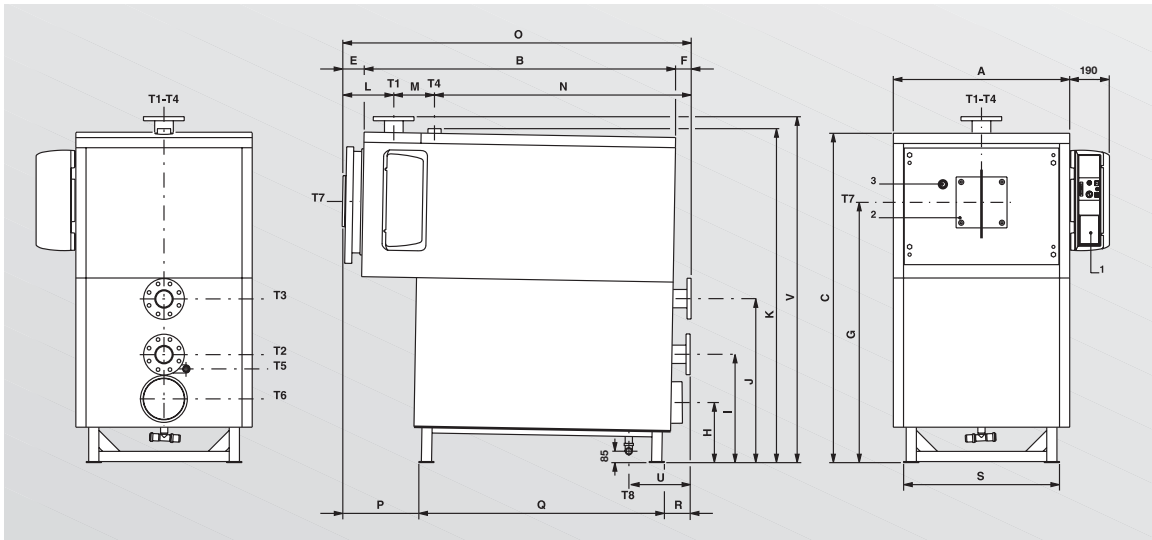

- Key:
- 1 - Panel board
 - 2 - Burner flange
 - 3 - Flame sight glass
 - T1 - C.H. flow
 - T2 - Low temperature C.H. return
 - T3 - High temperature C.H. return
 - T4 - Expansion vessel connection
 - T5 - Boiler drain
 - T6 - Chimney connection
 - T7 - Burner plate
 - T8 - Condensate drain

INOXIA GJ	S*	A	B	C	E	F	G	H	I	J	K	L	M	N	O	P	Q	R	U	V
Model	mm	mm	mm	mm	mm	mm	mm	mm	mm	mm	mm	mm	mm	mm	mm	mm	mm	mm	mm	mm
150	665	766	1295	1558	112	75	1243	283	489	719	1545	278	200	1004	1482	299	1005	178	328	1645
200	665	766	1295	1558	112	75	1243	283	489	719	1545	278	200	1004	1482	299	1005	178	328	1645
270	765	866	1530	1649	112	91	1309	300	536	809	1635	287	220	1226	1733	353	1205	175	355	1745
350	765	866	1530	1649	112	91	1309	300	536	809	1635	287	220	1226	1733	353	1205	175	355	1745
450	795	896	1952	1790	125	66	1415	328	590	845	1893	312	320	1511	2143	288	1666	189	400	1893
600	795	896	1952	1790	125	66	1415	328	590	845	1893	312	320	1511	2143	288	1666	189	400	1893
800	975	1076	2250	2075	140	78	1629	345	655	940	2178	341	340	1787	2468	364	1866	238	490	2178
1000	975	1076	2250	2075	140	78	1629	345	655	940	2178	341	340	1787	2468	364	1866	238	490	2178

* Dimension without casin

INOXIA GJ		150	200	270	350	450	600	800	1000	
Outputs										
NOMINAL INPUT	kW	140	186	253	327	420	560	746	934	
NOMINAL OUTPUT in condensation (Tm 30/Tr 50°C)	kW	150	200	270	350	450	600	800	1000	
NOMINAL OUTPUT (Tm 80/Tr 60°C)	kW	136,5	181,5	247,5	320,5	412,5	550	732,8	917,5	
Efficiency										
CATEGORIA DI RENDIMENTO (direttiva CEE 92/42)		★★★★	★★★★	★★★★	★★★★	★★★★	★★★★	★★★★	★★★★	
EFFICIENCY AT 100% load, in condensation mode.	%	107,1	107,5	107,1	107	107,1	107,1	107,2	107	
EFFICIENCY AT 30% load, in condensation mode	%	109	109	109	109	109	109	109	109	
EFFICIENCY AT 100% load, in condensation mode	%	97,5	97,5	97,8	98	98,2	98,2	98,2	98,2	
CASING HIT LOSSES	%	0,15	0,15	0,10	0,10	0,09	0,09	0,07	0,07	
Combustion and Hydraulic Performance										
CO ₂	%	10,2	10,2	10,5	10,5	10,5	10,5	10,5	10,5	
CONDENSATE PRODUCTION max	l/h	20,9	27,7	37,7	48,8	62,7	83,6	111,3	139,4	
MANOMETRIC HEAD AVAILABLE AT THE CHIMNEY **	mm c.a.	10	10	10	10	10	10	10	10	
SMOKE SIDE PRESSURE LOSSES	mm c.a.	10	15	14	23	18	32	30	45	
WATER SIDE PRESSURE LOSSES with 15 K ΔT	m c.a.	0,27	0,45	0,35	0,55	0,30	0,50	0,37	0,60	
MASSIVE SMOKE FLOW RATE	kg/h	203,3	270,1	353,8	463,1	594,8	793,1	1056,5	1322,7	
MAX. SMOKE TEMPERATURE (Boiler T. 80/60°C)	°C	48	46	44	40	36	36	36	36	
MAX. SMOKE TEMPERATURE (Boiler T. 50/30°C)	°C	20	20	20	20	20	20	20	20	
MAX. WORKING PRESSURE	bar	5	5	5	5	5	5	5	5	
WATER CONTENT	l	248	248	380	380	533	533	907	907	
Dimensions Connections and Weight										
FLOW / RETURN low and high temperature	T1/T2/T3	UNI 2278 PN16	65	65	80	80	100	100	125	125
EXPANSION VESSEL CONNECTION	T4	UNI 2278 PN16	1 1/2	1 1/2	2	2	65	65	80	80
BOILER DRAIN	T5	ISO 7/1	3/4	3/4	3/4	3/4	1	1	1	1
CHIMNEY CONNECTION	T6	Øl mm	180	180	200	200	250	250	300	300
BURNER CONNECTION	T7	Øi mm	180	180	180	180	210	210	270	270
CONDENSATE DRAIN	T8	Øe mm	40	40	40	40	40	40	40	40
DRY WEIGHT	kg	480	480	675	675	1090	1090	1650	1650	

** In combination with the most common burners.

