

INDUSTRIAL RANGE

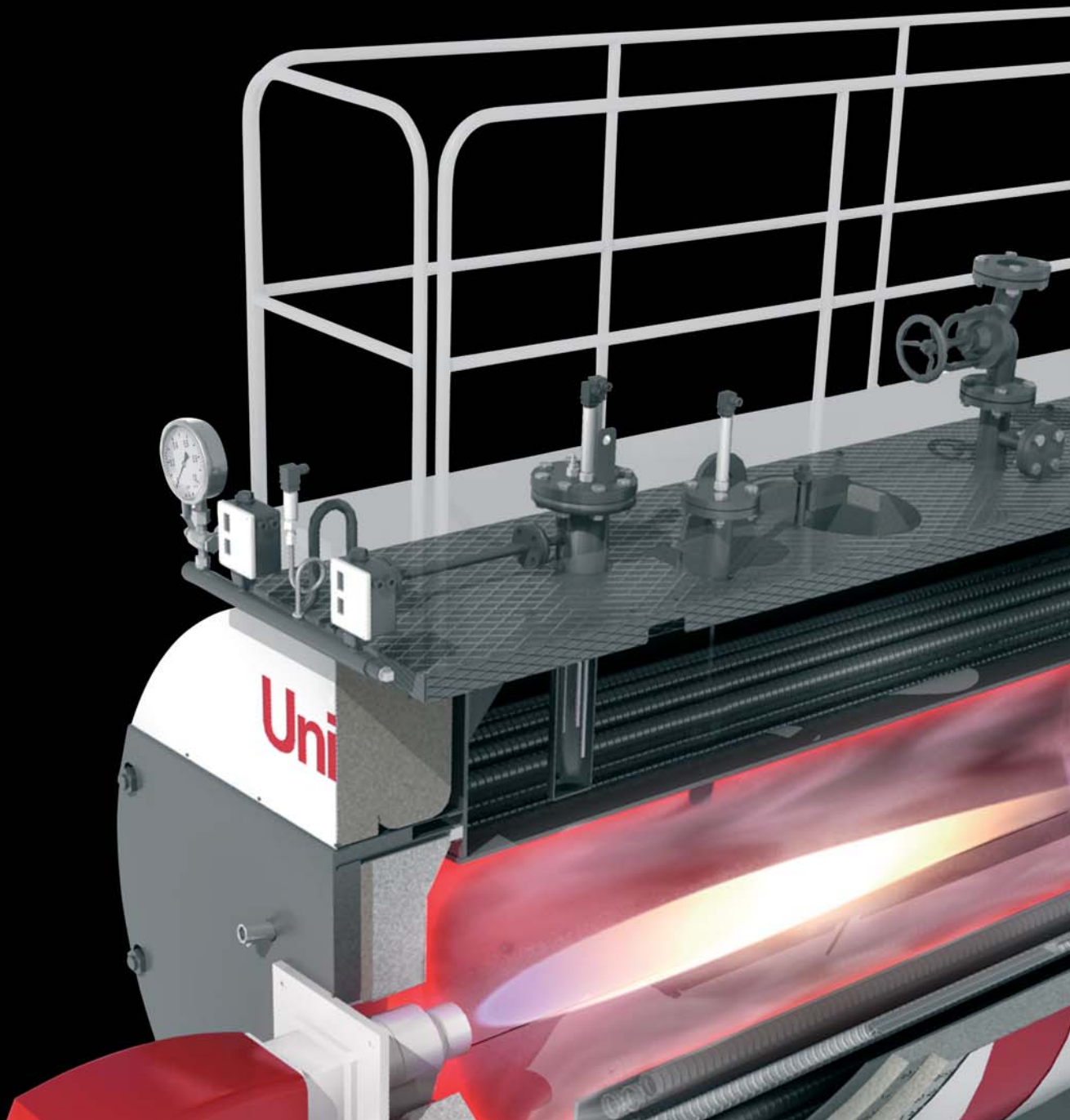

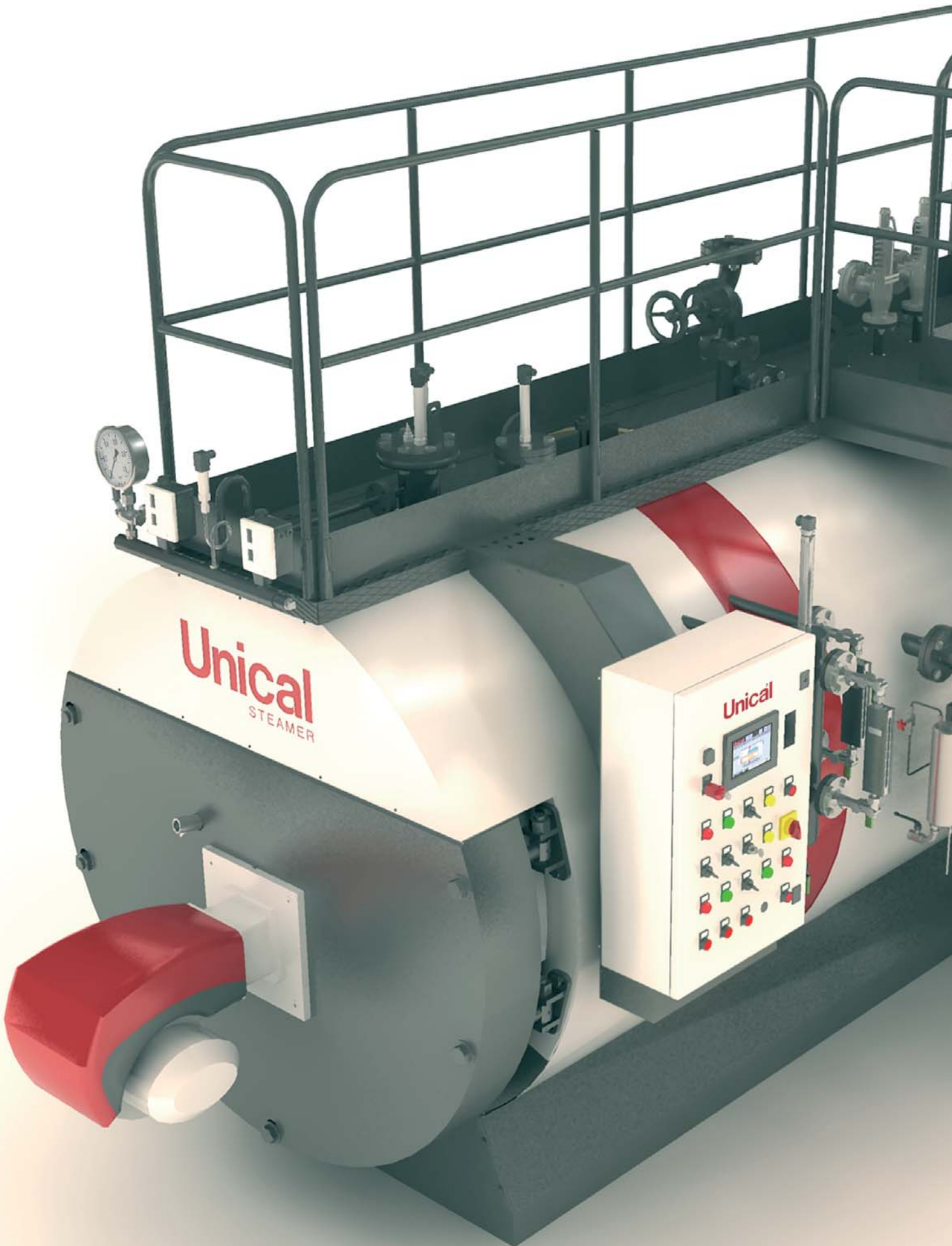

Contents

■ Low and high pressure, reversed flame, steam generators	BAHR'UNO	page 2
	BAHR'12/15	page 5
	BAHR'UNO HP	page 8
	BAHR'12/15 HP	page 11
	BAHR'UNO HP EC	page 14
	BAHR'12/15 HP EC	page 17
	■ High pressure, three pass steam generators	TRYPASS'12/15
■ Optional accessories for steam generators		page 26
■ Optional accessories for installation completion		page 31
■ Three pass hot water boilers	TERNOx	page 36
■ Reversed flame overheated water boilers	SÛHR'	page 38
■ Three pass overheated water boilers	TRYSÛHR'	page 40
■ Three pass diathermic oil boilers	DÏATHER'	page 42



BAHR'UNO

Enbloc, reversed flame, low pressure steam generator

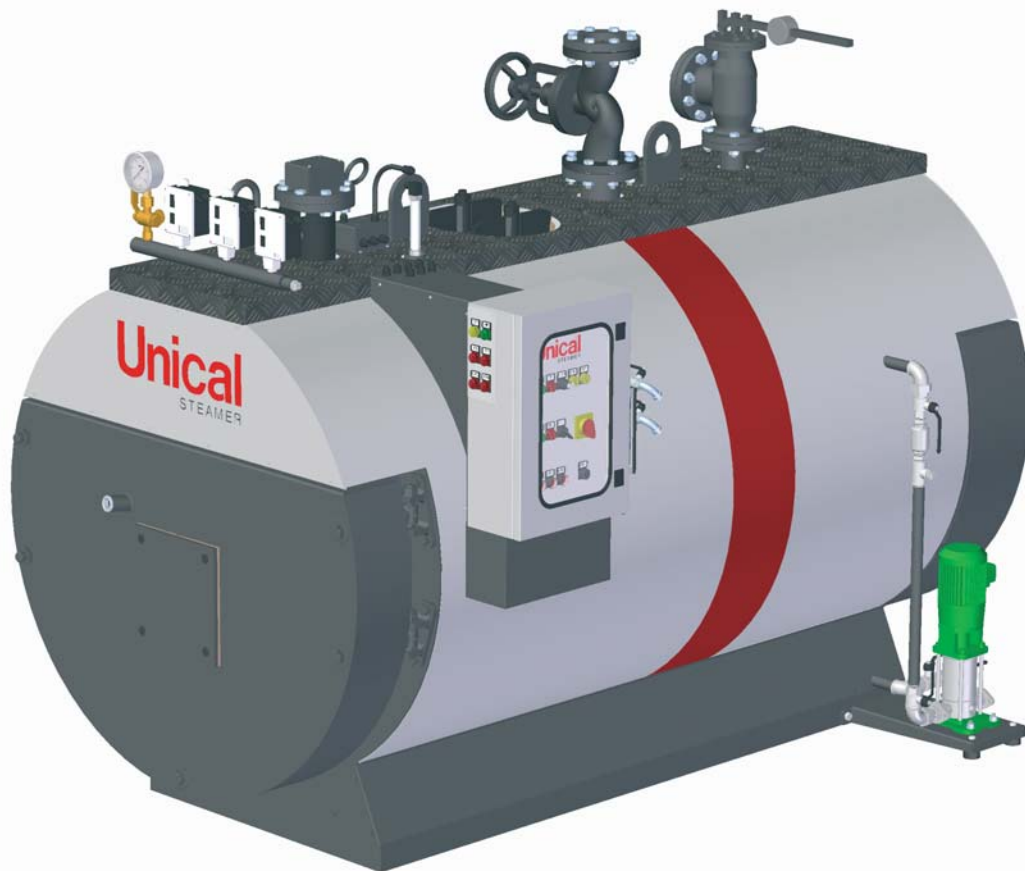

Low pressure steam generator, reversed flame and smoke pipe type, for a maximum design pressure PS = 1 bar, made of a wet bottom cylindrical furnace, sized to grant both, surface and combustion chamber low thermal loadings.

The range comprises **13 models** with a steam production **from 200 up to 3000 kg/h.**

CE certification in conformity with the European Directives: 97/23/CE - PED
2004/108/CE - EMC
2006/95/CE - LVD

International Protection Rating: IP55

- **FURNACE**
pressurized, wet bottom
- **TUBE BUNDLE**
with smoke pipes welded to the tube plates
- **TURBULATORS**
of proper shape, placed inside the tube bundle for the optimization of the heat exchange
- **FRONT DOOR**
of thick steel plate, insulated with refractory/insulating material
- **REAR SMOKE CHAMBER**
complete with a cleaning and access door, thermally insulated
- **INSULATION**
of the outer shell with a very thick, high density rock wool mattress
- **CASING**
in thick pre-painted steel sheet, with protective film
- **GANGWAY**
in checker plate, placed on the upper part
- **BASEMENT**
in welded steel profiles, to grant a stable support in the boiler house
- **PANEL BOARD**
in a box (protection degree IP 55), tested and certified, with all the necessary components for the automatic operation of the generator, included visual and sound alarms.

BAHR'UNO

Enbloc, reversed flame, low pressure steam generator

Standard-production equipment

- N. 1 manometer \varnothing 100 mm – scale: 0÷1,6 bar with 3 way cock for manometer calibration
- N. 2 working pressure switches
- N. 1 safety pressure switch with manual reset, CE PED certified
- N. 1 lever weighted safety valve
- N. 1 reflecting level indicator \varnothing 1/2", with purging and cut-off cocks
- N. 2 level test cocks
- N. 1 level automatic adjustment group
- N. 1 safety minimum level switch with auto-diagnosis, with manual reset, CE PED certified,
- N. 1 additional low level safety sensor, with manual reset
- N. 1 steam delivery valve
- N. 1 feeding group complete w/pump and motor, in vertical position
- N. 1 discharge group
- N. 1 BASIC model panel board (3N ~ 400 V – 50 Hz)
- N. 1 Turbulators kit

Equipment on demand

- KIT "SECOND PUMP FOR BOILER WATER FEEDING"
- KIT of "SAFETY ON MAXIMUM LEVEL"
- KIT of "SAFETY ON MINIMUM LEVEL"
- KIT "TDS (Total Dissolved Salts)"
- KIT "AUTOMATIC BOTTOM BLOW DOWN"
- KIT "24 hr" for standard generator
- KIT "72 hr" for standard generator
- Spring loaded safety valve
- Pre-drilled burner plate according to burner type
- Burner

Special versions

BAHR'UNO 24 hr

equipped with KIT 24 hr for standard generator, to get certification for boiler operation w/o continuous surveillance

BAHR'UNO 72 hr

equipped with KIT 72 hr for standard generator, to get certification for boiler operation w/o continuous surveillance

Technical Data

Model	Steam Production	Nominal Output *	Nominal Input	Max Working Pressure**	Water content at standard level	Total capacity	Smoke side press. losses	Burner head minimum length	Burner max blast tube diameter
	kg/h	kW	kW	bar	l	l	mbar	mm	mm
200	200	134	151	0,98	310	410	2,6	340	210
300	300	201	226	0,98	568	730	2,2	340	210
400	400	268	301	0,98	568	730	2,6	340	210
500	500	335	376	0,98	814	1040	2,8	340	240
600	600	402	452	0,98	814	1040	3,5	340	240
800	800	537	603	0,98	1160	1545	3,8	340	240
1000	1000	671	754	0,98	1160	1545	4,2	340	240
1250	1250	838	942	0,98	1663	2250	4,5	370	280
1500	1500	1006	1130	0,98	1663	2250	5,1	370	280
1750	1750	1174	1319	0,98	2140	2890	5,5	370	280
2000	2000	1341	1507	0,98	2140	2890	6,0	370	280
2500	2500	1677	1884	0,98	2970	4060	6,8	370	360
3000	3000	2012	2261	0,98	2970	4060	7,0	370	360

*With feeding water temperature = 70°C and pressure = 1 bar

** Setting value of safety valves

BAHR'UNO

Enbloc, reversed flame, low pressure steam generator

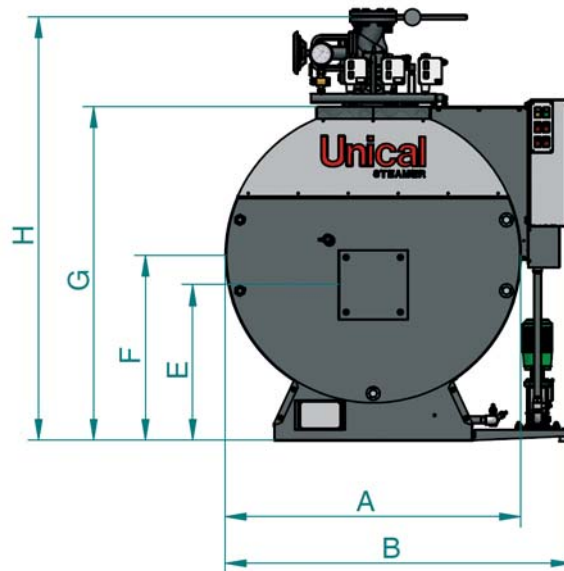
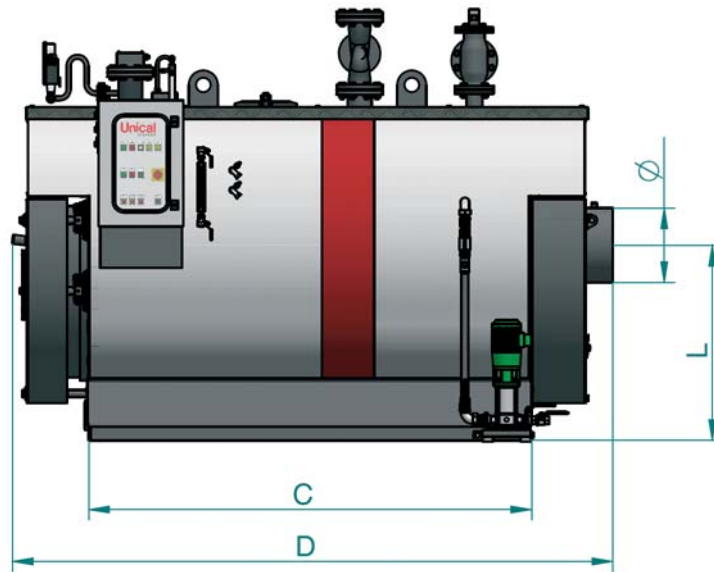

Dimensions

Model	A	B	C	D	E	F	G	H	L	Ø	Dry weight
	mm	mm	mm	mm	mm	mm	mm	mm	mm	mm	kg
200	1030	1360	1100	1865	580	695	1220	1485	725	219	1010
300	1150	1480	1550	2315	635	755	1340	1630	815	219	1330
400	1150	1480	1550	2315	635	755	1340	1630	815	219	1330
500	1270	1600	1750	2515	685	815	1460	1800	880	258	1630
600	1270	1600	1750	2515	685	815	1460	1800	880	258	1630
800	1410	1740	2120	2885	745	885	1600	1980	945	358	2130
1000	1410	1740	2120	2885	745	885	1600	1980	945	358	2130
1250	1555	1885	2527	3322	860	1005	1790	2220	1075	408	2740
1500	1555	1885	2527	3322	860	1005	1790	2220	1075	408	2740
1750	1680	2010	2750	3545	905	1070	1920	2350	1170	408	3360
2000	1680	2010	2750	3545	905	1070	1920	2350	1170	408	3360
2500	1950	2280	2830	3625	1080	1265	2250	2725	1410	508	4650
3000	1950	2280	2830	3625	1080	1265	2250	2725	1410	508	4650

BAHR'12/15

Enbloc, reversed flame, high pressure steam generator

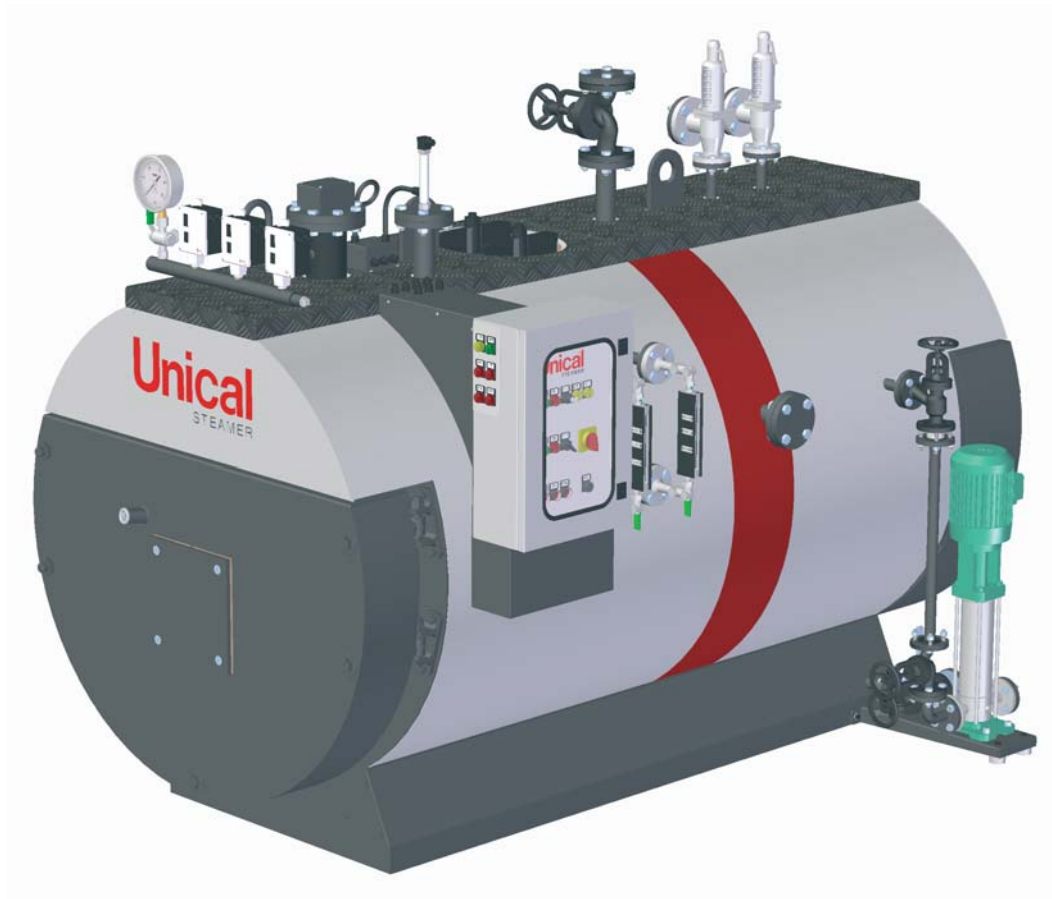

High pressure steam generator, reversed flame and smoke pipe type, for a maximum design pressure PS = 12 bar (14.7 bar for BAHR'15, supplied on request), made of a wet bottom cylindrical furnace, sized to grant both, surface and combustion chamber low thermal loadings.

The range comprises **14 models** with a steam production **from 300 up to 5000 kg/h.**

CE certification in conformity with the European Directives: 97/23/CE - PED
2004/108/CE - EMC
2006/95/CE - LVD

International Protection Rating: IP55

- **FURNACE**
pressurized, wet bottom
- **TUBE BUNDLE**
with smoke pipes welded to the tube plates
- **TURBULATORS**
of proper shape, placed inside the tube bundle for the optimization of the heat exchange
- **FRONT DOOR**
of thick steel plates, insulated with refractory/insulating material
- **REAR SMOKE CHAMBER**
complete with a cleaning and access door, thermally insulated
- **INSULATION**
of the outer shell with a very thick, high density rock wool mattress
- **CASING**
in thick pre-painted steel sheet, with protective film
- **GANGWAY**
in checker plate, placed on the upper part
- **BASEMENT**
in welded steel profiles, to grant a stable support in the boiler house
- **PANEL BOARD**
in a box (protection degree IP 55), tested and certified, with all the necessary components for the automatic operation of the generator, included visual and sound alarms.

BAHR'12/15

Enbloc, reversed flame, high pressure steam generator

Standard-production equipment

- N. 1 manometer Ø 150 mm – scale: 0÷16 bar with 3 way cock for manometer calibration
- N. 2 reflecting level indicator Ø 1/2" with purging and cut-off cocks
- N. 2 working pressure switches
- N. 1 safety pressure switch with manual reset, CE PED certified
- N. 1 level automatic adjustment group
- N. 1 safety minimum level switch with auto-diagnosis, with manual reset, CE PED certified
- N. 1 additional low level safety sensor, with manual reset on the panel board
- N. 2 spring loaded safety valves
- N. 1 steam delivery valve
- N. 1 feeding group complete w/pump and motor, in vertical position
- Valve assembly for feeding circuit, with relevant pipes already fitted
- Valve assembly for discharging circuit, with relevant pipes already fitted
- N. 1 BASIC model panel board (3N ~ 400 V – 50 Hz)
- N. 1 Turbulators kit

Equipment on demand

- KIT "SECOND PUMP FOR BOILER WATER FEEDING "
- KIT of "SAFETY ON MAXIMUM LEVEL"
- KIT of "SAFETY ON MINIMUM LEVEL"
- KIT "TDS (Total Dissolved Salts)"
- KIT "AUTOMATIC BOTTOM BLOW DOWN"
- KIT "24 hr" for standard generator
- KIT "72 hr" for standard generator
- KIT External economizer and modulating feeding group
- Pre-drilled burner plate according to burner type
- Burner
- Emergency feeding group (steam injector)

Special versions

BAHR'15

version with maximum working pressure of 14.7 bar

BAHR'12 /15 24 hr

equipped with KIT 24 hr, to get certification for boiler operation w/o continuous surveillance up to 24 hr

BAHR'12/15 72 hr

equipped with KIT 72 hr, to get certification for boiler operation w/o continuous surveillance up to 72 hr.

Technical Data

Model	Steam Production	Nominal Output *	Nominal Input	Max Working Pressure**	Water content at standard level	Total capacity	Smoke side press. losses	Burner head minimum length	Burner max blast tube diameter
	kg/h	kW	kW	bar	l	l	mbar	mm	mm
300	300	204	234	12 – 14,7	525	710	2,2	340	210
400	400	273	314	12 – 14,7	525	710	2,6	340	210
500	500	341	392	12 – 14,7	760	1015	2,8	340	240
600	600	409	470	12 – 14,7	760	1015	3,5	340	240
800	800	545	626	12 – 14,7	1080	1500	3,8	340	240
1000	1000	682	784	12 – 14,7	1080	1500	4,2	340	240
1250	1250	852	979	12 – 14,7	1555	2195	4,5	370	280
1500	1500	1022	1175	12 – 14,7	1555	2195	5,1	370	280
1750	1750	1193	1371	12 – 14,7	2005	2810	5,5	370	280
2000	2000	1363	1567	12 – 14,7	2005	2810	6,0	370	280
2500	2500	1704	1959	12 – 14,7	2890	3950	6,8	370	360
3000	3000	2045	2351	12 – 14,7	2890	3950	7,0	370	360
4000	4000	2726	3133	12 – 14,7	4155	5780	8,0	370	400
5000	5000	3408	3917	12 – 14,7	5800	7730	8,8	370	400

*With feeding water temperature = 80°C and pressure = 12 bar

** Setting value of safety valves

BAHR'12/15

Enbloc, reversed flame, high pressure steam generator

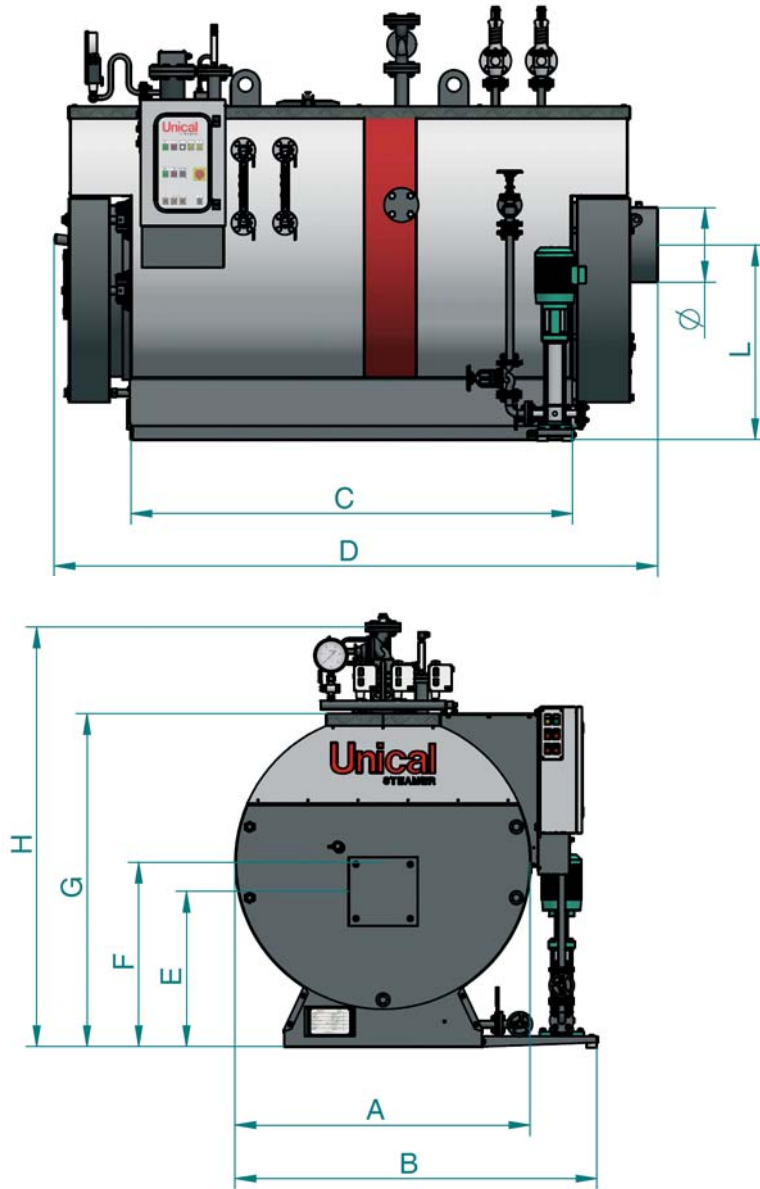

Dimensions

Model	A	B	C	D	E	F	G	H	L	ø	Dry weight
	mm	mm	mm	mm	mm	mm	mm	mm	mm	mm	kg
300	1150	1480	1550	2315	635	755	1340	1555	815	219	1600
400	1150	1480	1550	2315	635	755	1340	1555	815	219	1600
500	1270	1600	1750	2515	685	815	1460	1725	880	258	1940
600	1270	1600	1750	2515	685	815	1460	1725	880	258	1940
800	1410	1740	2120	2885	745	885	1600	1870	945	358	2700
1000	1410	1740	2120	2885	745	885	1600	1870	945	358	2700
1250	1555	1885	2527	3322	860	1005	1790	2095	1075	408	3500
1500	1555	1885	2527	3322	860	1005	1790	2095	1075	408	3500
1750	1680	2010	2750	3545	905	1070	1920	2225	1170	408	4300
2000	1680	2010	2750	3545	905	1070	1920	2225	1170	408	4300
2500	1950	2280	2830	3625	1080	1265	2250	2595	1410	508	6000
3000	1950	2280	2830	3625	1080	1265	2250	2595	1410	508	6000
4000	2180	2510	3300	4095	1170	1380	2480	2865	1500	608	8270
5000	2280	2610	3800	4595	1195	1405	2555	2990	1525	658	9700

BAHR'UNO HP

Enbloc, reversed flame, High Performance, low pressure steam generator



High Performance, low pressure steam generator, reversed flame and smoke pipe type, for a maximum design pressure PS = 1 bar, made of a wet bottom cylindrical furnace, sized to grant both, surface and combustion chamber low thermal loadings.

The range comprises **13 models** with a steam production **from 200 up to 3000 kg/h.**

CE certification in conformity with the European Directives: 97/23/CE - PED
2004/108/CE - EMC
2006/95/CE - LVD

International Protection Rating: IP55

- **FURNACE**
pressurized, wet bottom
- **TUBE BUNDLE**
with special ESALU* smoke pipes (Unical Patent),
to grant High Performances in terms of efficiency
- **BOILER PANEL BOARD UNICAL IML (Industrial Multi Logic)**
connected directly to all the electronic operation accessories, completely programmable (PLC), operator interface with touch screen display
- **Standard supplied with "KIT 24 hr" for operation without continuous surveillance up to 24 hrs**
- **FRONT DOOR**
of thick steel plate, insulated with refractory/insulating material
- **REAR SMOKE CHAMBER**
complete with a cleaning and access door, thermally insulated
- **INSULATION**
of the outer shell with a very thick, high density rock wool mattress
- **CASING**
in thick pre-painted steel sheet, with protective film
- **GANGWAY**
in checker plate, placed on the upper part
- **BASEMENT**
in welded steel profiles, to grant a stable support in the boiler house

*suitable only for gas operation

BAHR'UNO HP

Enbloc, reversed flame, High Performance, low pressure steam generator

Standard-production equipment

- N. 1 manometer \varnothing 100 mm – scale: 0÷1,6 bar with 3 way cock for manometer calibration
- N. 1 reflecting level indicator \varnothing 1/2" with purging and cut-off cocks
- N. 2 level test cocks
- N. 1 boiler pressure transducer for the control of the modulating gas burner
- N. 1 safety pressure switch, CE PED certified, with manual reset on the panel board
- N. 1 working pressure switch for emergency operation
- N. 1 level transducer (capacitive sensor) for the automatic water level regulation in the boiler
- N. 2 safety minimum level switches with auto-diagnosis, with manual reset, CE PED certified, for burner lockout, on the panel board
- N. 1 lever weighted safety valve
- N. 1 steam delivery valve
- N. 1 feeding group complete w/pump and motor, in vertical version
- Valve assembly for feeding circuit, with relevant pipes already fitted
- Valve assembly for discharging circuit, with relevant pipes already fitted
- Electronic panel board IML (Industrial Multi Logic)

Equipment on demand

- Spring loaded safety valve
- KIT "SECOND PUMP FOR BOILER WATER FEEDING "
- KIT of "SAFETY ON MAXIMUM LEVEL"
- KIT "TDS (Total Dissolved Salts)"
- KIT "AUTOMATIC BOTTOM BLOW DOWN"
- KIT "72 hr"
- KIT Economizer
- Pre-drilled burner plate according to burner type
- Burner

Special versions

BAHR'UNO HP 72 hr

equipped with KIT 72 hr, to get certification for boiler operation w/o continuous surveillance

BAHR'UNO HPO

The HPO version is equipped with six-sector pipes (Unical Patent) and Economizer, suitable for oil operation

BAHR'UNO HPO 72 hr

As the previous one, but equipped with KIT 72 hr, to get certification for boiler operation w/o continuous surveillance up to 72 hrs

Technical Data

Model	Steam Production	Nominal Output *	Nominal Input	Max Working Pressure**	Water content at standard level	Total capacity	Smoke side press. losses	Burner head minimum length	Burner max blast tube diameter
	kg/h	kW	kW	bar	l	l	mbar	mm	mm
200	200	134	141	0,98	310	410	3,0	340	210
300	300	201	212	0,98	568	730	3,7	340	210
400	400	268	282	0,98	568	730	4,2	340	210
500	500	335	353	0,98	814	1040	4,5	340	240
600	600	402	423	0,98	814	1040	5,1	340	240
800	800	537	565	0,98	1160	1545	5,1	340	240
1000	1000	671	706	0,98	1160	1545	5,8	340	240
1250	1250	838	882	0,98	1663	2250	5,9	370	280
1500	1500	1006	1059	0,98	1663	2250	6,7	370	280
1750	1750	1174	1236	0,98	2140	2890	6,7	370	280
2000	2000	1341	1412	0,98	2140	2890	7,6	370	280
2500	2500	1677	1765	0,98	2970	4060	7,6	370	360
3000	3000	2012	2118	0,98	2970	4060	8,6	370	360

*With feeding water temperature = 70°C and pressure = 1 bar

** Setting value of safety valves

BAHR'UNO HP

Enbloc, reversed flame, High Performance, low pressure steam generator

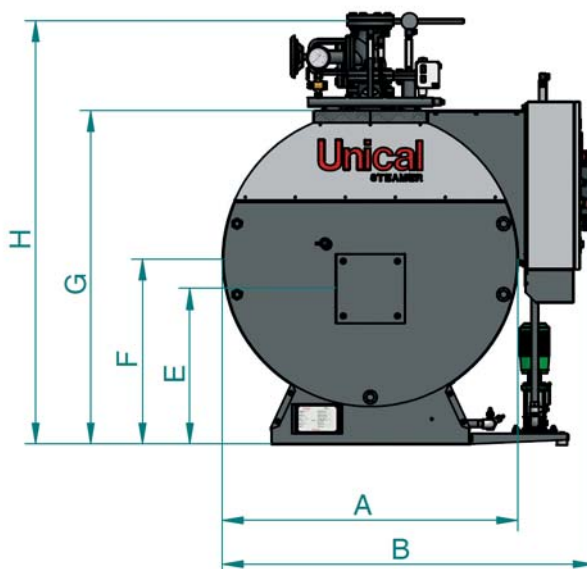
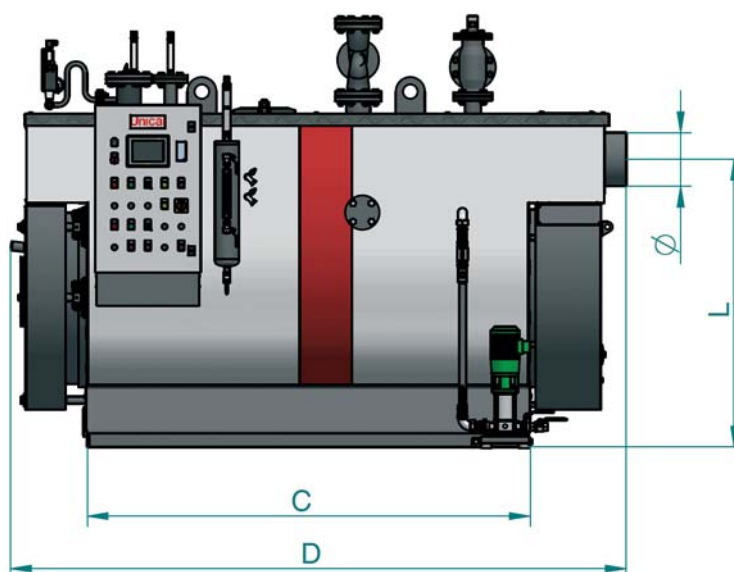

Dimensions

Model	A	B	C	D	E	F	G	H	L	Ø	Dry Weight
	mm	mm	mm	mm	mm	mm	mm	mm	mm	mm	kg
200	1030	1360	1100	2350	580	695	1220	1485	725	219	1060
300	1150	1480	1550	2550	635	755	1340	1630	1167	219	1380
400	1150	1480	1550	2550	635	755	1340	1630	1167	219	1380
500	1270	1600	1750	2960	685	815	1460	1800	1266	219	1730
600	1270	1600	1750	2960	685	815	1460	1800	1266	219	1730
800	1410	1740	2120	3437	745	885	1600	1980	1379	258	2290
1000	1410	1740	2120	3437	745	885	1600	1980	1379	258	2290
1250	1555	1885	2527	3740	860	1005	1790	2220	1417	308	2990
1500	1555	1885	2527	3740	860	1005	1790	2220	1417	308	2990
1750	1680	2010	2750	3860	905	1070	1920	2350	1482	358	3710
2000	1680	2010	2750	3860	905	1070	1920	2350	1482	358	3710
2500	1950	2280	2830	4370	1080	1265	2250	2725	1677	408	5250
3000	1950	2280	2830	4370	1080	1265	2250	2725	1677	408	5250

BAHR'12/15 HP

Enbloc, reversed flame, High Performance, high pressure steam generator

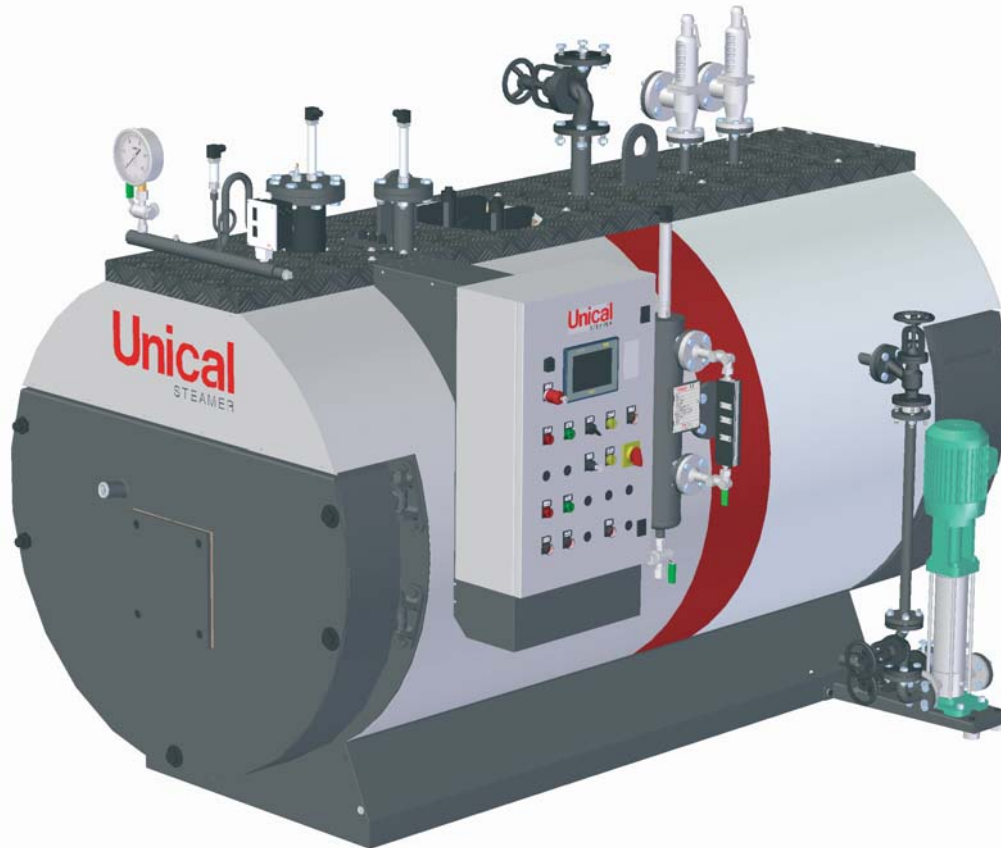

High pressure steam generator, reversed flame and smoke pipe type, for a maximum design pressure PS = 12 bar (14.7 bar for BAHR'15, supplied on request), made of a wet bottom cylindrical furnace, sized to grant both, surface and combustion chamber low thermal loadings.

The range comprises **14 models** with a steam production **from 300 up to 5000 kg/h.**

CE certification in conformity with the European Directives: 97/23/CE - PED
2004/108/CE - EMC
2006/95/CE - LVD

International Protection Rating: IP55

- **FURNACE**
pressurized, wet bottom
- **TUBE BUNDLE**
with special ESALU* smoke pipes (Unical Patent),
to grant High Performances in terms of efficiency
- **Standard supplied with “KIT 24 hr” for operation
without continuous surveillance up to 24 hrs**
- **BOILER PANEL BOARD UNICAL IML (Industrial
Multi Logic)**
connected directly to all the electronic operation
accessories, completely programmable (PLC),
operator interface with touch screen display
- **FRONT DOOR**
of thick steel plates, insulated with refractory/
insulating material
- **REAR SMOKE CHAMBER**
complete with a cleaning and access door, thermally
insulated
- **INSULATION**
of the outer shell with a very thick, high density rock
wool mattress
- **CASING**
in thick pre-painted steel sheet, with protective film
- **GANGWAY**
in checker plate, placed on the upper part
- **BASEMENT**
in welded steel profiles, to grant a stable support in
the boiler house

* suitable only for gas operation

BAHR'12/15 HP

Enbloc, reversed flame, High Performance, high pressure steam generator

Standard-production equipment

- N. 1 manometer \varnothing 150 mm – scale: 0÷16 bar – with 3 way cock for manometer calibration
- N. 1 reflecting level indicator \varnothing 1/2" with purging and cut-off cocks
- N. 1 boiler pressure transducer for the control of the modulating gas burner
- N. 1 safety pressure switch with manual reset, CE PED certified
- N. 1 working pressure switch for emergency operation
- N. 1 level transducer (capacitive sensor) for the automatic water level regulation in the boiler
- N. 2 safety minimum level switch with auto-diagnosis, with manual reset on the panel board, CE PED certified
- N. 2 spring loaded safety valves
- N. 1 steam delivery valve
- N. 1 feeding group complete w/pump and motor, in vertical position
- Valve assembly for feeding circuit, with relevant pipes already fitted
- Valve assembly for discharging circuit, with relevant pipes already fitted
- Electronic panel board IML (Industrial Multi Logic)

Equipment on demand

- KIT "SECOND PUMP FOR BOILER WATER FEEDING "
- KIT of "SAFETY ON MAXIMUM LEVEL"
- KIT of "SAFETY ON MINIMUM LEVEL"
- KIT "TDS (Total Dissolved Salts)"
- KIT "AUTOMATIC BOTTOM BLOW DOWN"
- KIT "72 hr"
- KIT economizer
- Pre-drilled burner plate according to burner type
- Burner
- Emergency feeding group (steam injector)

Special Versions

BAHR'12/15 HP 72 hr

Equipped with KIT 72 hr, to get certification for boiler operation w/o continuous surveillance up to 72 hrs

BAHR'12/15 HPO

The HPO version is equipped with six-sector pipes (Unical Patent) and Economizer, suitable for oil operation

BAHR'12/15 HPO 72 hr

As the previous version, but equipped with KIT 72 hr, to get certification for boiler operation w/o continuous surveillance up to 72 hr.

Technical Data

Model	Steam Production	Nominal Output *	Nominal Input	Max Working Pressure**	Water content at standard level	Total capacity	Smoke side press. losses	Burner head minimum length	Burner max blast tube diameter
	kg/h	kW	kW	bar	l	l	mbar	mm	mm
300	300	204	222	12 – 14,7	525	710	3,7	340	210
400	400	273	297	12 – 14,7	525	710	4,2	340	210
500	500	341	371	12 – 14,7	760	1015	4,5	340	240
600	600	409	445	12 – 14,7	760	1015	5,1	340	240
800	800	545	592	12 – 14,7	1080	1500	5,1	340	240
1000	1000	682	741	12 – 14,7	1080	1500	5,8	340	240
1250	1250	852	926	12 – 14,7	1555	2195	5,9	370	280
1500	1500	1022	1111	12 – 14,7	1555	2195	6,7	370	280
1750	1750	1193	1297	12 – 14,7	2005	2810	6,7	370	280
2000	2000	1363	1482	12 – 14,7	2005	2810	7,6	370	280
2500	2500	1704	1852	12 – 14,7	2890	3950	7,6	370	360
3000	3000	2045	2223	12 – 14,7	2890	3950	8,6	370	360
4000	4000	2726	2963	12 – 14,7	4155	5780	9,6	370	400
5000	5000	3408	3704	12 – 14,7	5800	7730	10,4	370	400

*With feeding water temperature = 80°C and pressure = 12 bar

**Setting value of safety valves

BAHR'12/15 HP

Enbloc, reversed flame, High Performance, high pressure steam generator

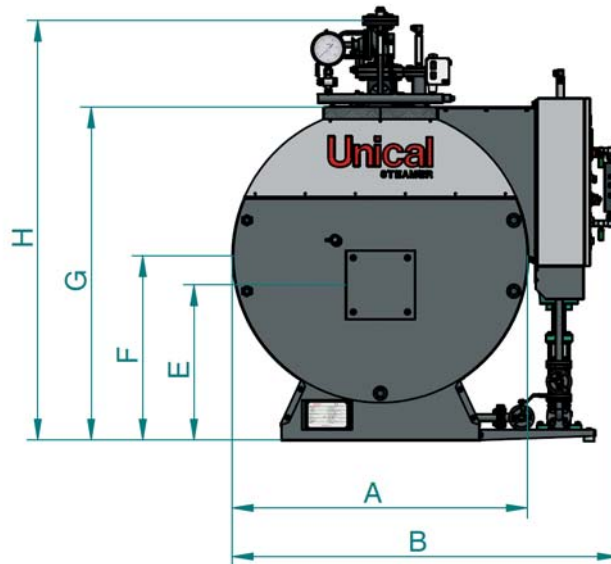
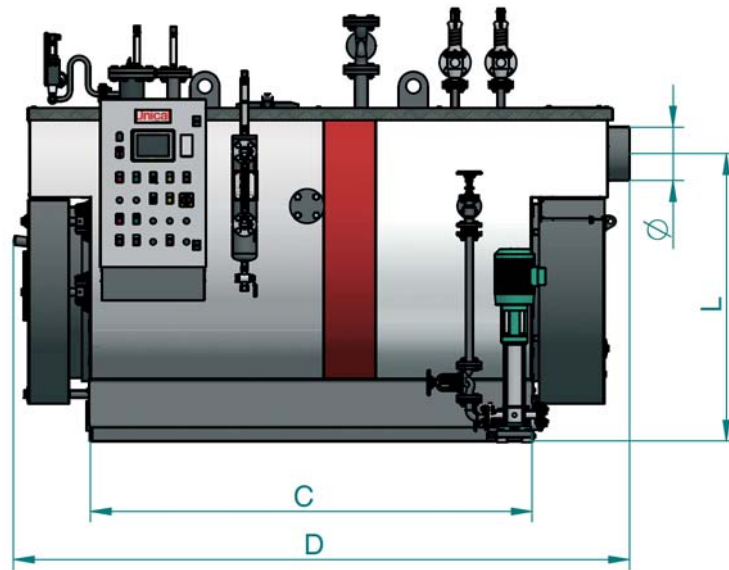

Dimensions

Model	A	B	C	D	E	F	G	H	L	Ø	Dry weight
	mm	mm	mm	mm	mm	mm	mm	mm	mm	mm	kg
300	1150	1480	1550	2350	635	755	1340	1555	1167	219	1650
400	1150	1480	1550	2350	635	755	1340	1555	1167	219	1650
500	1270	1600	1750	2550	685	815	1460	1725	1266	219	2040
600	1270	1600	1750	2550	685	815	1460	1725	1266	219	2040
800	1410	1740	2120	2960	745	885	1600	1870	1379	258	2860
1000	1410	1740	2120	2960	745	885	1600	1870	1379	258	2860
1250	1555	1885	2527	3437	860	1005	1790	2095	1417	308	3750
1500	1555	1885	2527	3437	860	1005	1790	2095	1417	308	3750
1750	1680	2010	2750	3740	905	1070	1920	2225	1482	358	4650
2000	1680	2010	2750	3740	905	1070	1920	2225	1482	358	4650
2500	1950	2280	2830	3860	1080	1265	2250	2595	1677	408	6600
3000	1950	2280	2830	3860	1080	1265	2250	2595	1677	408	6600
4000	2180	2510	3300	4370	1170	1380	2480	2865	1792	458	9030
5000	2280	2610	3800	4940	1195	1405	2555	2990	1817	508	10590

BAHR'UNO HP EC

Enbloc, reversed flame, High Performance, low pressure steam generator with economizer



High Performance, low pressure steam generator, reversed flame and smoke pipe type, for a maximum design pressure PS = 1 bar, made of a wet bottom cylindrical furnace, sized to grant both, surface and combustion chamber low thermal loadings.

The range comprises **13 models** with a steam production **from 200 up to 3000 kg/h.**

CE certification in conformity with the European Directives: 97/23/CE - PED
2004/108/CE - EMC
2006/95/CE - LVD

International Protection Rating: IP55

- **FURNACE**
pressurized, wet bottom
- **TUBE BUNDLE**
with special ESALU* smoke pipes (Unical Patent),
to grant High Performances in terms of efficiency
- **Standard supplied with "KIT 24 hr" for operation
without continuous surveillance up to 24 hrs**
- **KIK EC (Kit Economizer)**
standard supplied for an additional increase of
the efficiency, placed in the rear smoke chamber,
keeping unchanged the dimensions if compared with
the HP range
- **BOILER PANEL BOARD UNICAL IML
(Industrial Multi Logic)**
connected directly to all the electronic operation
accessories, completely programmable (PLC),
operator interface with touch screen display
- **FRONT DOOR**
of thick steel plates, insulated with refractory/
insulating material
- **REAR SMOKE CHAMBER**
complete with a cleaning and access door, thermally
insulated
- **INSULATION**
of the outer shell with a very thick, high density rock
wool mattress
- **CASING**
in thick pre-painted steel sheet, with protective film
- **GANGWAY**
in checker plate, placed on the upper part
- **BASEMENT**
in welded steel profiles, to grant a stable support in
the boiler house

*suitable only for gas operation

BAHR'UNO HP EC

Enbloc, reversed flame, High Performance, low pressure steam generator with economizer

Standard-production equipment

- N. 1 manometer \varnothing 100 mm – scale: 0÷1,6 bar with 3 way cock for manometer calibration
- N. 1 reflecting level indicator \varnothing 1/2" with purging and cut-off cocks
- N. 2 level test cocks
- N. 1 boiler pressure transducer for the control of the modulating gas burner
- N. 1 safety pressure switch, CE PED certified, with manual reset on the panel board
- N. 1 working pressure switch for emergency operation
- N. 1 level transducer (capacitive sensor) for the automatic water level regulation in the boiler
- N. 2 safety minimum level switches with auto-diagnosis, with manual reset on the panel board CE PED certified
- N. 1 lever weighted safety valve
- N. 1 steam delivery valve
- N. 1 feeding group complete w/pump and motor, in vertical version
- Valve assembly for feeding circuit, with relevant pipes already fitted
- Valve assembly for discharging circuit, with relevant pipes already fitted
- Electronic panel board IML (Industrial Multi Logic)
- KIT Economizer EC

Equipment on demand

- Spring loaded safety valve
- KIT "SECOND PUMP FOR BOILER WATER FEEDING "
- KIT of "SAFETY ON MAXIMUM LEVEL"
- KIT "TDS (Total Dissolved Salts)"
- KIT "AUTOMATIC BOTTOM BLOW DOWN"
- KIT "72 hr"
- Pre-drilled burner plate according to burner type
- Burner

Special versions

BAHR'UNO HP EC 72 hr

equipped with KIT 72 hr, to get certification for boiler operation w/o continuous surveillance up to 72 hrs

BAHR'UNO HPO EC

The HPO version is equipped with six-sector smoke pipes (Unical Patent) and Economizer, suitable for oil operation

BAHR'UNO HPO EC 72 hr

As the previous one, but equipped with KIT 72 hr, to get certification for boiler operation w/o continuous surveillance up to 72 hrs

Technical Data

Model	Steam Production	Nominal Output *	Nominal Input	Max Working Pressure**	Water content at standard level	Total capacity	Smoke side press. losses	Burner head minimum length	Burner max blast tube diameter
	kg/h	kW	kW	bar	l	l	mbar	mm	mm
200	200	134	137	0,98	310	410	3,8	340	210
300	300	201	205	0,98	568	730	4,5	340	210
400	400	268	273	0,98	568	730	5,0	340	210
500	500	335	342	0,98	814	1040	5,3	340	240
600	600	402	410	0,98	814	1040	5,9	340	240
800	800	537	548	0,98	1160	1545	5,9	340	240
1000	1000	671	685	0,98	1160	1545	6,6	340	240
1250	1250	838	855	0,98	1663	2250	6,6	370	280
1500	1500	1006	1027	0,98	1663	2250	7,4	370	280
1750	1750	1174	1198	0,98	2140	2890	7,4	370	280
2000	2000	1341	1368	0,98	2140	2890	8,3	370	280
2500	2500	1677	1711	0,98	2970	4060	8,2	370	360
3000	3000	2012	2053	0,98	2970	4060	9,2	370	360

*With feeding water temperature = 70°C and pressure = 1 bar

** Setting value of safety valves

BAHR'UNO HP EC

Enbloc, reversed flame, High Performance, low pressure steam generator with economizer

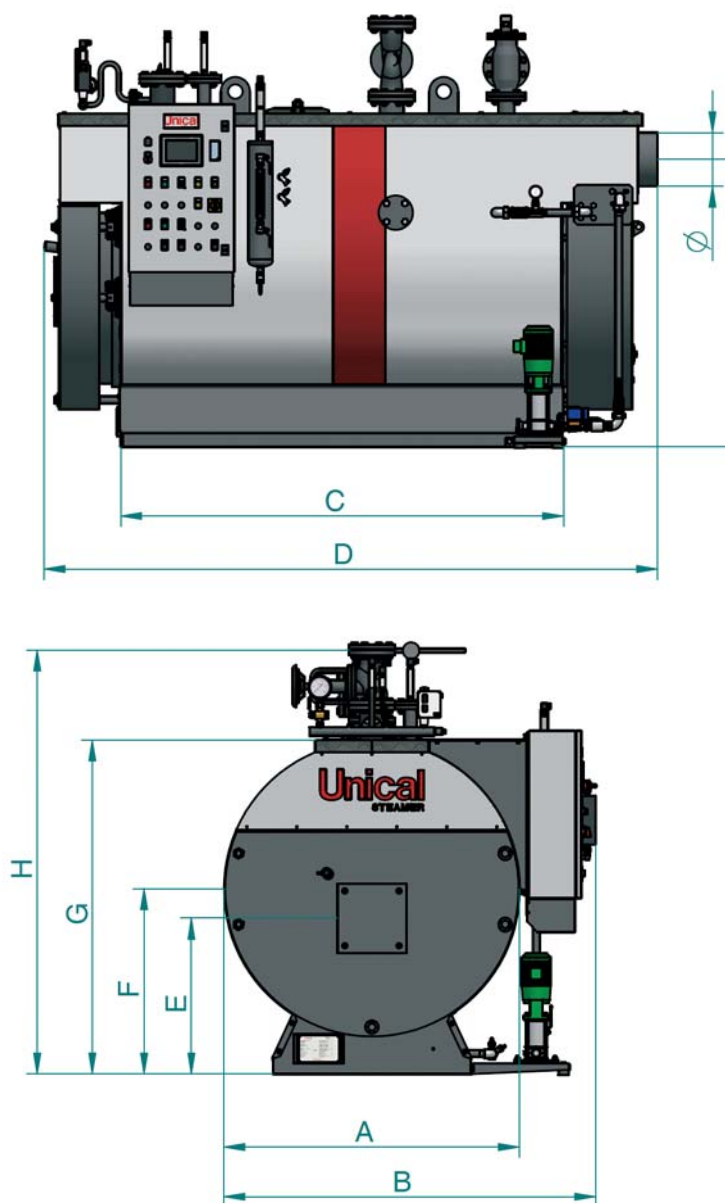

Dimensions

Model	A	B	C	D	E	F	G	H	L	Ø	Dry weight
	mm	mm	mm	mm	mm	mm	mm	mm	mm	mm	kg
200	1030	1360	1100	2350	580	695	1220	1485	725	219	1100
300	1150	1480	1550	2550	635	755	1340	1630	1167	219	1430
400	1150	1480	1550	2550	635	755	1340	1630	1167	219	1430
500	1270	1600	1750	2960	685	815	1460	1800	1266	219	1790
600	1270	1600	1750	2960	685	815	1460	1800	1266	219	1790
800	1410	1740	2120	3437	745	885	1600	1980	1379	258	2360
1000	1410	1740	2120	3437	745	885	1600	1980	1379	258	2360
1250	1555	1885	2527	3740	860	1005	1790	2220	1417	308	3070
1500	1555	1885	2527	3740	860	1005	1790	2220	1417	308	3070
1750	1680	2010	2750	3860	905	1070	1920	2350	1482	358	3800
2000	1680	2010	2750	3860	905	1070	1920	2350	1482	358	3800
2500	1950	2280	2830	4370	1080	1265	2250	2725	1677	408	5350
3000	1950	2280	2830	4370	1080	1265	2250	2725	1677	408	5350

BAHR'12/15 HP EC

Enbloc, reversed flame, High Performance, high pressure steam generator with economizer

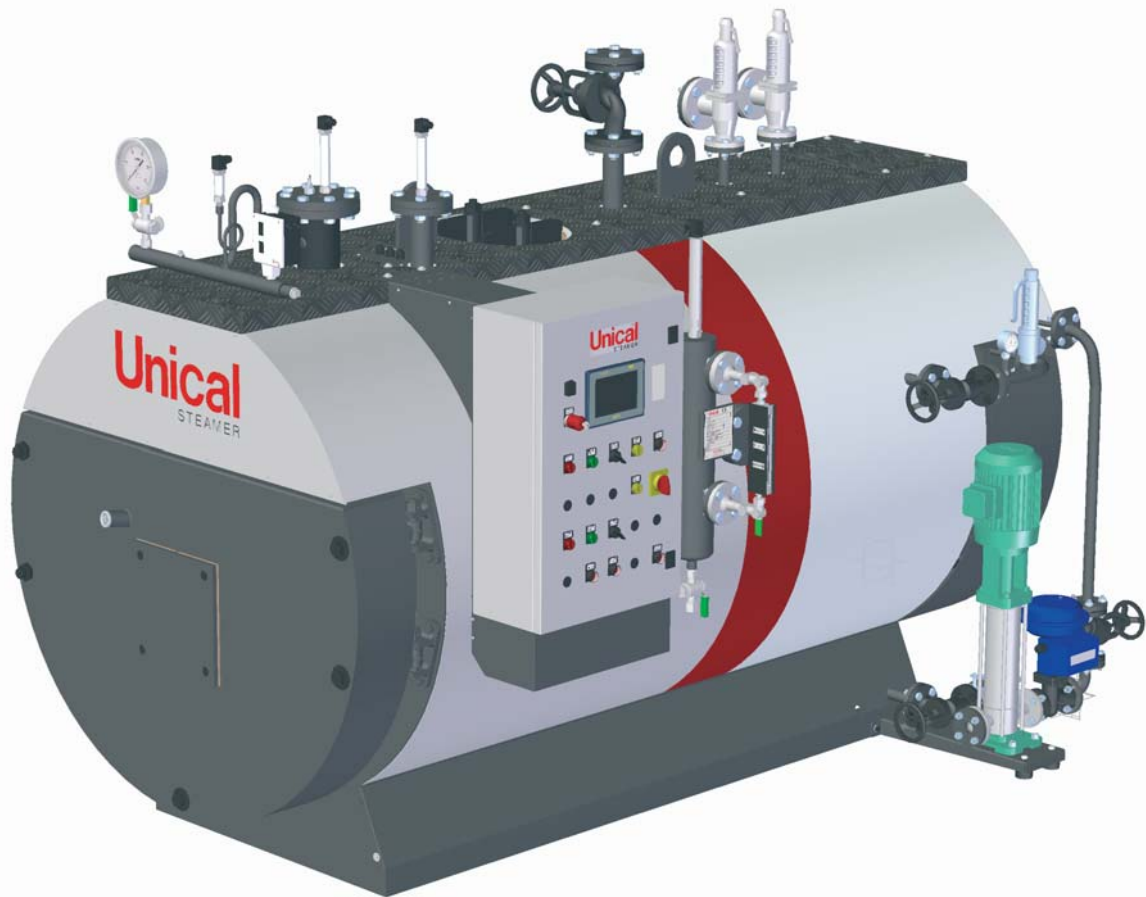

High pressure steam generator, reversed flame and smoke pipe type, for a maximum design pressure PS = 12 bar (14.7 bar for BAHR'15, supplied on request), made of a wet bottom cylindrical furnace, sized to grant both, surface and combustion chamber low thermal loadings.

The range comprises **14 models** with a steam production **from 300 up to 5000 kg/h.**

CE certification in conformity with the European Directives: 97/23/CE - PED
2004/108/CE - EMC
2006/95/CE - LVD

International Protection Rating: IP55

- **FURNACE**
pressurized, wet bottom
- **TUBE BUNDLE**
with special ESALU* smoke pipes (Unical Patent), to grant High Performances in terms of efficiency
- **Standard supplied with "KIT 24 hr" for operation without continuous surveillance up to 24 hrs**
- **KIK EC (Kit Economizer)**
standard supplied for an additional increase of the efficiency, placed in the rear smoke chamber, keeping unchanged the dimensions if compared with the HP range
- **BOILER PANEL BOARD UNICAL IML (Industrial Multi Logic)**
connected directly to all the electronic operation accessories, completely programmable (PLC), operator interface with touch screen display
- **FRONT DOOR**
of thick steel plates, insulated with refractory/insulating material
- **REAR SMOKE CHAMBER**
complete with a cleaning and access door, thermally insulated
- **INSULATION**
of the outer shell with a very thick, high density rock wool mattress
- **CASING**
in thick pre-painted steel sheet, with protective film
- **GANGWAY**
in checker plate, placed on the upper part
- **BASEMENT**
in welded steel profiles, to grant a stable support in the boiler house

* suitable only for gas operation

BAHR'12/15 HP EC

Enbloc, reversed flame, High Performance, high pressure steam generator with economizer

Standard-production equipment

- N. 1 manometer \varnothing 150 mm – scale: 0÷16 bar – with 3 way cock for manometer calibration
- N. 1 reflecting level indicator \varnothing 1/2" with purging and cut-off cocks
- N. 1 boiler pressure transducer for the control of the modulating gas burner
- N. 1 safety pressure switch with manual reset, CE PED certified
- N. 1 level transducer (capacitive sensor) for the automatic water level regulation in the boiler
- N. 2 safety minimum level switch with auto-diagnosis, with manual reset on the panel board, CE PED certified
- N. 2 Spring loaded safety valves
- N. 1 steam delivery valve
- N. 1 feeding group complete w/pump and motor, in vertical position
- Valve assembly for feeding circuit and relevant piping already mounted
- Valve assembly for discharging circuit and relevant piping already mounted
- Electronic panel board IML (Industrial Multi Logic)
- Kit Economizer EC

Equipment on demand

- KIT "SECOND PUMP FOR BOILER WATER FEEDING "
- KIT of "SAFETY ON MAXIMUM LEVEL"
- KIT "TDS (Total Dissolved Salts)"
- KIT "AUTOMATIC BOTTOM BLOW DOWN"
- KIT "72 hr"
- Pre-drilled burner plate according to burner type
- Burner
- Emergency feeding group (steam injector)

Special versions

BAHR'12 (15) HP EC (HPO EC)

The HPO EC version is equipped with six-sector pipes (Unical Patent) and Economizer, suitable for oil operation

BAHR'12 (15) HP EC (HPO EC) 72 hr

As the previous version, but equipped with KIT 72 hr, to get certification for boiler operation w/o continuous surveillance up to 72 hr.

Technical Data

Model	Steam Production	Nominal Output *	Nominal Input	Max Working Pressure**	Water content at standard level	Total capacity	Smoke side press. losses	Burner head minimum length	Burner max blast tube diameter
	kg/h	kW	kW	bar	l	l	mbar	mm	mm
300	300	204	213	12 – 14,7	525	710	4,5	340	210
400	400	273	284	12 – 14,7	525	710	5,0	340	210
500	500	341	355	12 – 14,7	760	1015	5,3	340	240
600	600	409	426	12 – 14,7	760	1015	5,9	340	240
800	800	545	568	12 – 14,7	1080	1500	5,9	340	240
1000	1000	682	710	12 – 14,7	1080	1500	6,6	340	240
1250	1250	852	888	12 – 14,7	1555	2195	6,6	370	280
1500	1500	1022	1065	12 – 14,7	1555	2195	7,4	370	280
1750	1750	1193	1243	12 – 14,7	2005	2810	7,4	370	280
2000	2000	1363	1420	12 – 14,7	2005	2810	8,3	370	280
2500	2500	1704	1775	12 – 14,7	2890	3950	8,2	370	360
3000	3000	2045	2130	12 – 14,7	2890	3950	9,2	370	360
4000	4000	2726	2840	12 – 14,7	4155	5780	10,2	370	400
5000	5000	3408	3550	12 – 14,7	5800	7730	11,0	370	400

*With feeding water temperature = 80°C and pressure = 12 bar

**Setting value of safety valves

BAHR'12/15 HP EC

Enbloc, reversed flame, High Performance, high pressure steam generator with economizer

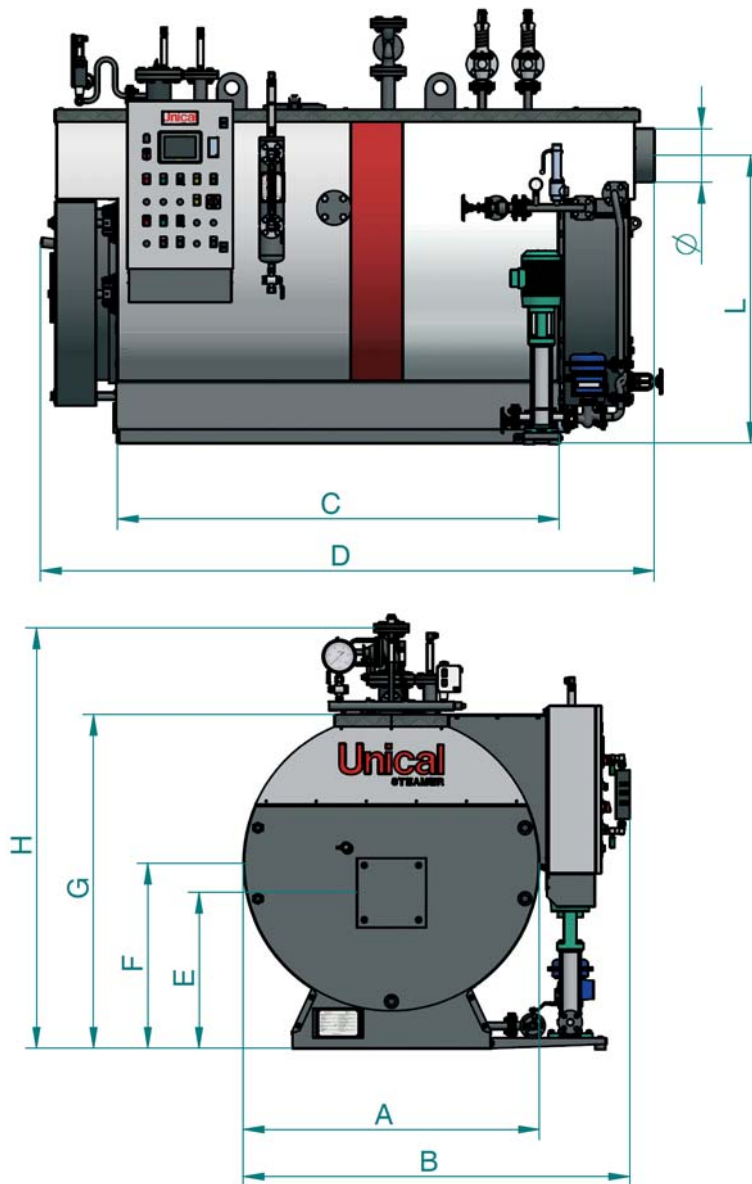

Dimensions

Model	A	B	C	D	E	F	G	H	L	ø	Dry weight
	mm	mm	mm	mm	mm	mm	mm	mm	mm	mm	kg
300	1150	1480	1550	2350	635	755	1340	1555	1167	219	1700
400	1150	1480	1550	2350	635	755	1340	1555	1167	219	1700
500	1270	1600	1750	2550	685	815	1460	1725	1266	219	2100
600	1270	1600	1750	2550	685	815	1460	1725	1266	219	2100
800	1410	1740	2120	2960	745	885	1600	1870	1379	258	2930
1000	1410	1740	2120	2960	745	885	1600	1870	1379	258	2930
1250	1555	1885	2527	3437	860	1005	1790	2095	1417	308	3830
1500	1555	1885	2527	3437	860	1005	1790	2095	1417	308	3830
1750	1680	2010	2750	3740	905	1070	1920	2225	1482	358	4740
2000	1680	2010	2750	3740	905	1070	1920	2225	1482	358	4740
2500	1950	2280	2830	3860	1080	1265	2250	2595	1677	408	6700
3000	1950	2280	2830	3860	1080	1265	2250	2595	1677	408	6700
4000	2180	2510	3300	4370	1170	1380	2480	2865	1792	458	9140
5000	2280	2610	3800	4940	1195	1405	2555	2990	1817	508	10710

HP / HP EC - ADVANTAGES

Low pressure steam generators – Steam production at continuous max. capacity (c.m.c.) 1000 kg/h				
BAHR'UNO range				
BAHR'UNO HP range (w/ESALU pipe)				
BAHR'UNO HP EC range (with ESALU pipes + Kit EC)				
Hypothesis of energy saving (only for natural gas operation)				
Range BAHR'UNO	Nominal Output	Nominal Input	Hourly gas consumption*	Total saving on 10 year operation Working 2500 hours/year**
Units Version	kW	kW	Stm ³ /h	euro
Standard	671	754	79,04	-
HP	671	706	74,00	37.735,75
HP EC	671	685	71,80	54.245,25

Output and steam production referred to feeding water temperature = 70°C and steam pressure = 1 bar

High pressure steam generators – Steam production at continuous max. capacity (c.m.c.) 1000 kg/h				
BAHR'12 range				
BAHR'12 HP range (with ESALU pipes)				
BAHR'12 HP EC range (with ESALU pipes + Kit EC)				
Hypothesis of energy saving (only for natural gas operation)				
Range BAHR'12	Nominal Output	Nominal Input	Hourly gas consumption*	Total saving on 10 year operation Working 2500 hours/year**
Units Version	kW	kW	Stm ³ /h	euro
Standard	682	784	82,18	-
HP	682	741	77,67	33.805,03
HP EC	682	710	74,42	58.176,10

Output and steam production referred to feeding water temperature = 80°C and steam pressure = 12 bar

*N.C.V. of the Natural Gas: 9.54 kWh/stm³

**Actual cost of the Nat. Gas = 0,30/m³

Running costs and environment protection

The smoke pipes ESALU (Unical Patent), suitable for the gas operation, that constitute the tube bundle, favour a very high heat exchange and are made by pipes having, inside, special inserts of different types and shapes, calculated considering the variation of the smoke volume during the way inside the pipe.

The adoption of the pipes ESALU allowed to obtain high performances (high efficiencies), with high reduction of the running costs, fuel consumption and polluting emissions in the atmosphere.

Standard fitted for the gas fired steam generators.

A special version of pipes, with six-sector inserts, is fitted for the oil or dual fuel fired steam generators.



TRYPASS'

Enbloc, three pass, smoke pipe type, high pressure steam generator

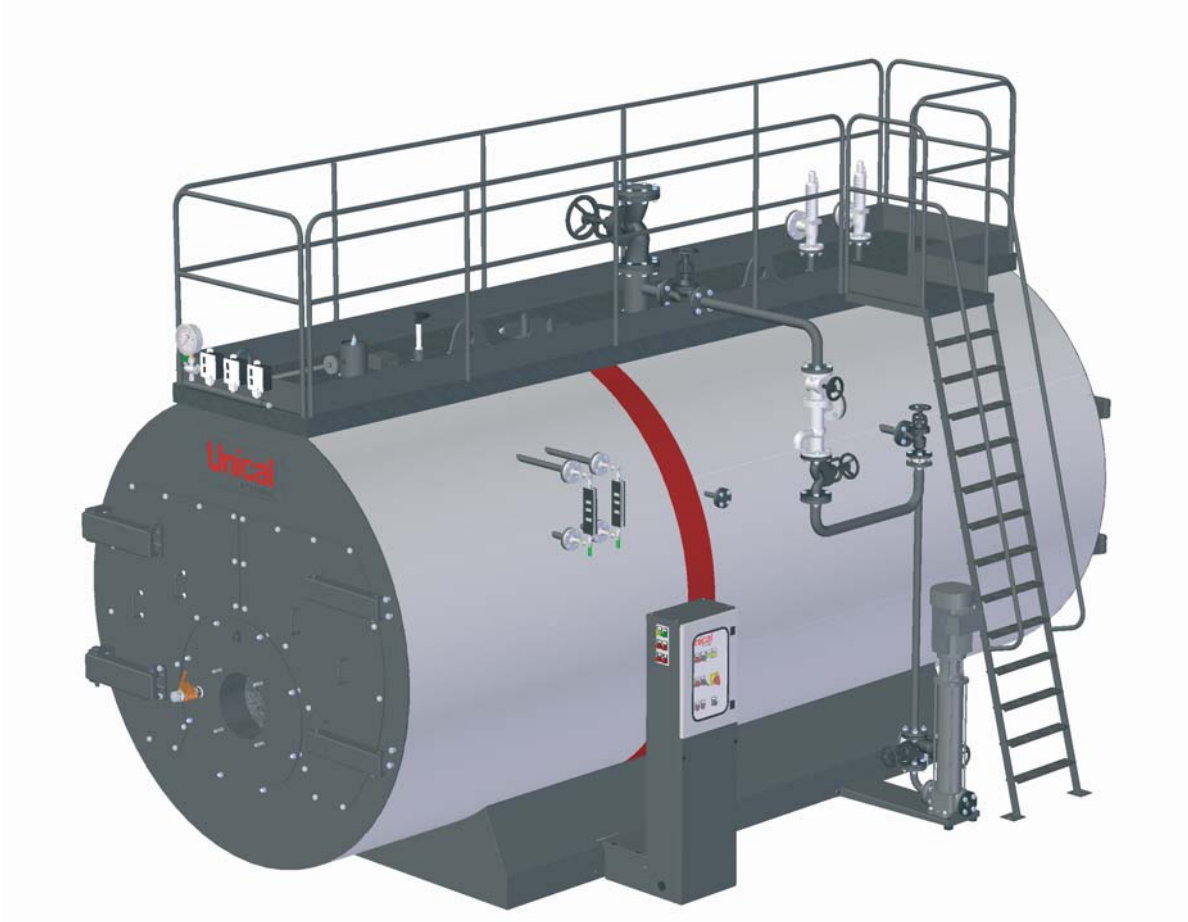

Enbloc, three pass, smoke pipe type, horizontal, high pressure steam generator, for design pressure PS = 12/15 bar, made of a wet bottom cylindrical furnace, sized to grant both, surface and combustion chamber low thermal loadings. A high water content and a wide evaporating surfaces grant high reliability, constant steam production and the possibility of strong drawing peaks.

Optimum efficiencies, without using turbulators, and low polluting emissions with the use of Low NOx burners. The range comprises **18 models**, with a steam production **from 2000 to 17250 kg/h**.

■ TWO SELF-CLEANING SIGHT GLASSES

placed on the front and rear part of the steam generator

■ FRONT DOORS

in welded steel plates, fitted on hinges for a fast opening, insulated with two thick refractory layers of different materials

■ REAR SMOKE CHAMBER

in welded steel plates, conveniently fitted and equipped with suitable cleaning doors and horizontal smoke outlet

■ LADDER AND GANGWAY

standard supplied for all the models

■ OUTER SHELL INSULATION

made of a high density and thick rock wool mattress, bound with thermosetting resins

■ CASING

made of thick aluminium sheet

■ EQUIPMENT DEVICES

for operation, control and safety, according to the rules in force, are standard supplied, with the panel board manufactured according to IEC norms, with a protection degree IP 55, fitted to one side of boiler frame and electrically connected with all the electrical accessories.

TRYPASS'

Enbloc, three pass, smoke pipe type, high pressure steam generator

Standard-production equipment

- N. 1 manometer \varnothing 150 mm – scale: 0÷16 bar – with 3 way cock for manometer calibration
- N. 2 reflecting level indicators, with purging and cut-off cocks
- N. 2 working pressure switches
- N. 1 safety pressure switch, CE PED certified, with manual reset on the panel board
- N. 1 automatic group for level control
- N. 1 safety minimum level switch with auto-diagnosis, with manual reset on the panel board, CE PED certified
- N. 1 additional minimum level safety sensor, with manual reset on the panel board, for burner lockout
- N. 2 Spring loaded safety valves
- N. 1 steam delivery valve
- N. 1 feeding group complete w/pump and motor, in vertical position
- Emergency feeding group (steam injector)
- Valve assembly for feeding circuit and relevant piping already mounted
- Valve assembly for discharging circuit and relevant piping already mounted
- N. 1 BASIC model panel board (3 Phase + N ~ 400 V – 50 Hz)
- Ladder and gangway

Technical Data

Model	Steam Production	Nominal Output *	Nominal Input	Max Working Pressure**	Water content at standard level	Total capacity	Smoke side press. losses	Burner head minimum length
	kg/h	kW	kW	bar	lt	lt	mbar	mm
2000 Low NOx	2000	1531	1363	12-15	6060	7360	5,5	450
2500	2500	1704	1936	12-15	6060	7360	9	450
3000 Low NOx	3000	2045	2285	12-15	7810	9195	6,5	500
3750	3750	2534	2847	12-15	7810	9195	10	500
4000 Low NOx	4000	2726	3080	12-15	9890	12215	6,0	500
5000	5000	3408	3873	12-15	9890	12215	11	500
5000 Low NOx	5000	3408	3808	12-15	11700	14550	7,5	500
6250	6250	4259	4785	12-15	11700	14550	11,5	500
6000 Low NOx	6000	4089	4569	12-15	12800	15900	9,0	550
7500	7500	5111	5743	12-15	12800	15900	15	550
8000 Low NOx	8000	5452	6058	12-15	16500	20100	11,0	550
10000	10000	6815	7572	12-15	16500	20100	16	550
10000 Low NOx	10000	6815	7572	12-15	20170	25150	13,0	600
12500	12500	8519	9466	12-15	20170	25150	20	600
12000 Low NOx	12000	8178	9087	12-15	22400	28800	16,0	600
14400	14400	9814	10904	12-15	22400	28800	23	600
15000 Low NOx	15000	10223	11359	12-15	25800	33300	21,0	700
17250	17250	11756	13435	12-15	25800	33300	28	700

*With feeding water temperature = 80°C and pressure = 12 bar

**Setting value of safety valves

Equipment on demand

- KIT “SECOND PUMP FOR BOILER WATER FEEDING “
- KIT of “SAFETY ON MAXIMUM LEVEL”
- KIT of “SAFETY ON MINIMUM LEVEL”
- KIT “TDS (Total Dissolved Salts)”
- KIT “AUTOMATIC BOTTOM BLOW DOWN”
- KIT “24 hr”
- KIT “72 hr”
- Electronic panel board IML (Industrial Multi Logic)
- Kit external Economizer and modulating feeding group
- Pre-drilled burner plate according to burner type
- Burner

Special versions for all the models

TRYPASS'12 24 hr

equipped with KIT 24 hr for standard generator, to get certification for boiler operation w/o continuous surveillance up to 24 hrs

TRYPASS'12 72 hr

equipped with KIT 72 hr for standard generator, to get certification for boiler operation w/o continuous surveillance up to 72 hrs

TRYPASS'12 PRE

with combustion air pre-heater

TRYPASS'

Enbloc, three pass, smoke pipe type, high pressure steam generator

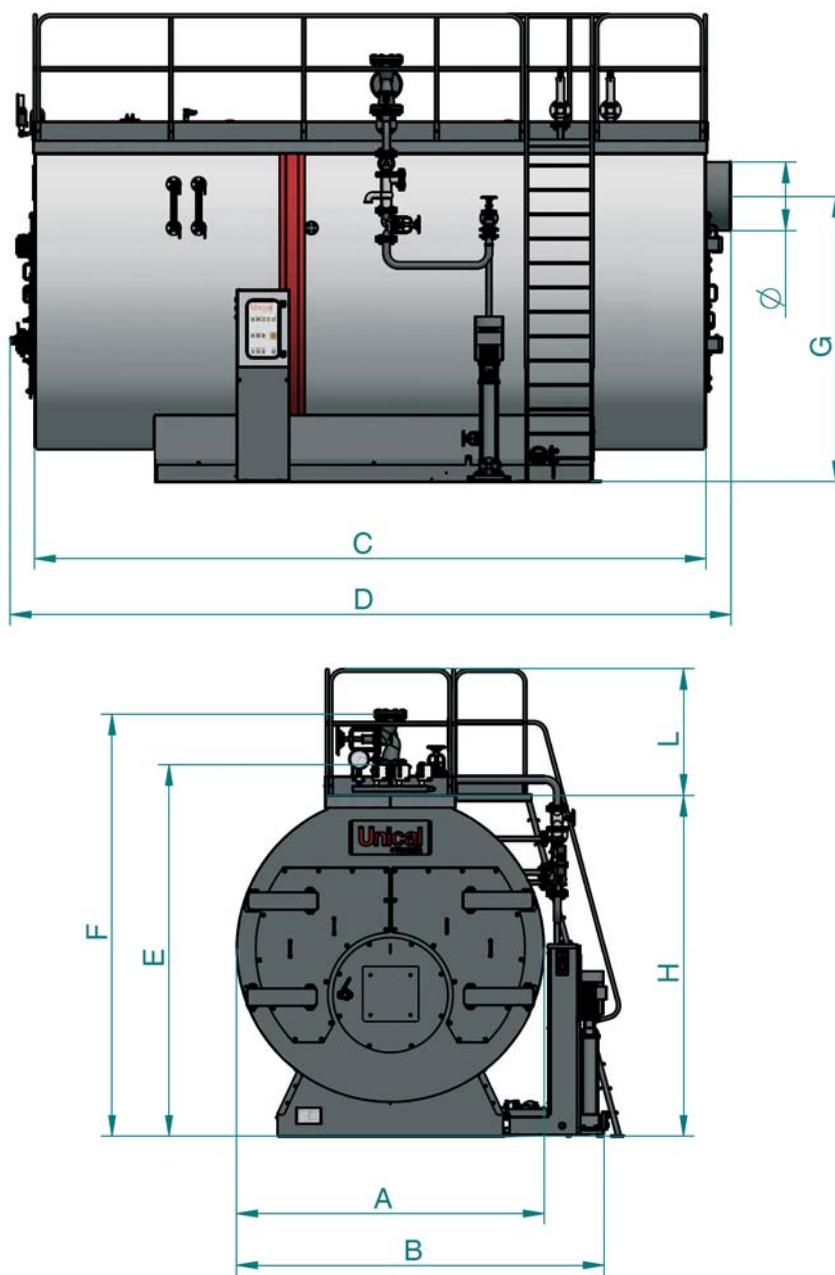

Dimensions

Model	A	B	C	D	E	F	G	H	L	ø
	mm	mm	mm	mm	mm	mm	mm	mm	mm	mm
2000 Low NOx/2500	2100	2460	4520	4910	2620	2935	2075	2380	1000	408
3000 Low NOx/3750	2250	2610	5020	5410	2775	3130	2110	2530	1000	508
4000 Low NOx/5000	2450	2810	5370	5760	2975	3375	2280	2730	1000	558
5000 Low NOx/6250	2600	2960	5620	6010	3120	3610	2475	2880	1000	608
6000 Low NOx/7500	2680	3040	5820	6210	3200	3685	2530	2960	1000	658
8000 Low NOx/10000	2850	3210	6620	7010	3325	3810	2560	3080	1000	708
10000 Low NOx/12500	3000	3360	7020	7410	3370	3855	2640	3200	1000	808
12000 Low NOx/14400	3200	3560	7220	7610	3470	4070	2750	3350	1000	858
15000 Low NOx/17250	3450	3810	7420	7810	3700	4300	2960	3580	1000	908

PANEL BOARD IML

Industrial Multi Logic

Simplicity and functionality

The regulation of the boiler is given in charge to a new panel board with electronic components that allows to get numerous advantages, among which:

- Multiple logic operation;
- Simplicity of use;
- Efficient regulation;
- Complete check of all the requested functionalities;
- Homologation for **24/72 hrs** exemption;

The IML “system” is realized with components that allow its modular management. Both, the harness and the electronic control software are so designed that the system can work in many configurations.

The main aesthetical novelty is the combination of the signalling lamps, for operation and safety, with a **touch-screen display** and the synoptic representation of the boiler.

The use of an electronic unit, programmable through **PLC**, allows to reach an elevated complexity in the operation logic of the generator, guaranteeing a more intelligent and complete management.

The electronic unity is endowed with different inputs and outputs that can check more functions of the generator at the same time and in a more articulated way, if compared with an electromechanical panel board.

The panel board manages completely all the working and safety parameters during the operation periods without continuous supervision, up to a maximum of 72 hrs.

Operator side panel with touch-screen display

The use of a graphic screen allows to represent in the main page of the menu, the generator in operation, with, schematized, the main control devices.

The touch-screen display allows to use virtual keys of direct access to the planning and regulation pages.

The graphic representation, through symbols, results therefore intuitive and of easy use.

Hardware and system expandibility

The basic system is composed of:

- a central unit (CPU)
- operator side panel (display)
- module of additional inputs

The **display** is the interface toward the operator and acts both, as output device (visualization and signals) and input device (commands introduction).

The **central unit** is predisposed for the connection to additional expansion units.

The **expansion** allows:

- to realize cascade boiler systems (with Master-Slave logic);
- to connect the generator to a supervision system (SCADA);



- to connect the control via GSM for remoting an alarm signal;
- to check other devices present on the plant (with other additional modules);
- to update the software for “upgrade” or changes in the plant.

Modulation

The panel board IML allows the management of the modulating of the burner without necessity of the modulating kit fitted on burner; besides, it allows the level modulation through the signal coming from the capacitive sensor supplied as standard.

Service

The IML panel board allows the function of the “driven service” (SAFE SERVICE) for the execution of the routine controls by the person authorized for the supervision, after the expiration of the “exemption period”.

The check results are filed in an inside database, exportable on file of mass through the USB port in front of the panel board.

Installation

The panel board is supplied with rapid multi-pole connections that make easy the installation on board of the generator. Safety

- The electronic regulator only replaces the regulation components;
- The panel is programmed for the indication of the alarm signals on the screen; the management of the boiler safeties remains of electromechanical type.
- On the panel board, furthermore, are fitted the components that allow, when necessary, the manual operation of the generator.

OPTIONAL KITS

Optional kits for steam generators

MINIMUM LEVEL SAFETY KIT

MINIMUM LEVEL SAFETY SWITCH FOR BOILER WATER
“FAIL SAFE” type, with CE PED certificate

Composition of the Kit

- N. 1 safety sensor 1/2”
- N. 1 stainless steel sensor electrode
- N. 1 safety controller with auto-diagnosis
- Electrical components



MAXIMUM LEVEL SAFETY KIT

MAXIMUM LEVEL SAFETY SWITCH FOR BOILER WATER
“FAIL SAFE” type, with CE PED certificate

Composition of the Kit

- N. 1 safety sensor 1/2”
- N. 1 stainless steel sensor electrode
- N. 1 safety controller with auto-diagnosis
- Electrical components



OPTIONAL KITS

Optional kits for steam generators

KIT TDS

SALTNESS CONTROL GROUP FOR BOILER WATER
AND SURFACE DRAIN with REGULATOR

Composition of the Kit

- N. 1 conductivity transducer with temperature compensation for measurement of TDS
- N. 1 TDS regulator
- N. 1 fitting 90° DN 50 – DN 20
- N. 1 surface drain valve DN 20, electrically or pneumatically actuated
- Pilot solenoid valve EV310B 2,0B G18F pilot 3/2 (only for pneumatic actuation)
- Electrical components



KIT AUTOMATIC DRAIN

BOILER BOTTOM AUTOMATIC DRAIN GROUP
PNEUMATICALLY ACTUATED

Composition of the Kit

- N. 1 automatic drain valve DN 25 or DN 40, electrically or pneumatically actuated with fast opening lever
- Pilot solenoid valve EV310B 2,0B G18F pilot 3/2 (only for pneumatic actuation)
- Electrical components



OPTIONAL KITS

Optional kits for steam generators

KIT 24 hr

KIT for certification of the steam generator operation WITHOUT CONTINUOUS SURVEILLANCE up to 24 hrs

Composition of the Kit

- A 2nd BOILER WATER MINIMUM LEVEL SAFETY SWITCH, "FAIL SAFE" type, with CE PED certificate
- Electrical components



KIT 72 hr

KIT for certification of the steam generator for operation WITHOUT CONTINUOUS SURVEILLANCE up to 72 hrs

Composition of the Kit

- KIT 24 hr (not necessary for HP versions)
- MAXIMUM LEVEL SAFETY KIT
- KIT TDS
- AUTOMATIC DRAIN KIT



OPTIONAL KITS

Optional kits for steam generators

KIT EC

ECONOMIZER KIT FOR STEAM GENERATORS, RANGE
BAHR'12 HP ^{(1) (2)}

Composition of the Kit

- Exchange battery with finned carbon steel pipes
- Modulating valve (Inverter starting per model 2000)
- Transformation piping
- Thermometer

(1) Only for gas fired boilers - (2) Inverter as per model 2000



KIT OF 2nd WATER PUMP

KIT OF 2nd BOILER WATER FEEDING PUMP

Composition of the Kit

- A 2nd feeding motor pump
- Gate valve
- No return valve
- Piping
- Modified IML panel board
- Electrical components



OPTIONAL KITS

Optional kits for steam generators

SAMPLE COOLER

COOLING TANK KIT FOR WATER SAMPLING

Composition of the Kit

- Cooler of boiler water sample
- Piping and connection valves
- Supporting bracket



INSTALLATION ACCESSORIES

EECO - Economizer for the preheating of the feeding water

External economizing group for the preheating of the feeding water for high pressure steam generators (12 bar).

Efficiency recovery : $\geq 4\%$

Carbon steel finned pipe battery suitable for gas fired boilers. Max working pressure up to 12 bar.

Technical Data

Boiler suffix	Boiler Nominal Output	Produzione vapore	Steam production Economizer model	Economizer code
EECO	kW	kg/h	EECO	
1000	682	1000	EECO 800 - 1000	
1250	852	1250	EECO 1250 - 2000	
1500	1022	1500	EECO 1250 - 2000	
1750	1193	1750	EECO 1250 - 2000	
2000	1363	2000	EECO 1250 - 2000	
2500	1704	2500	EECO 2500 - 3000	
3000	2045	3000	EECO 2500 - 3000	
4000	2726	4000	EECO 4000 - 5000	
5000	3408	5000	EECO 4000 - 5000	

Upon request EECO models for TRYPASS' 12/15 steam generators

Standard-production equipment

- External economizing group, complete with chimney connection and insulation, with carbon steel finned pipe battery, suitable for gas fired steam generators
- Pressure safety valve
- Gate valves
- Manometer
- Thermometer
- Modulating feeding group

INSTALLATION ACCESSORIES

DETE - Thermo-physical Deaerator

THERMOPHYSICAL DEAERATOR FOR LOW PRESSURE STEAM GENERATORS

Construction according to the European Directive 97/23/CE, art. 3, par. 3

Technical Data

Model	Degassed water flow rate		Volume		Feeding water pressure	Design pressure	Degassed water temperature
	min	max	utile	totale			
DETE	kg/h	kg/h	m ³	m ³	bar	bar	°C
1000	300	1500	700	1000	10 ÷ 12	0,5	105
2000	1750	3000	1400	2000	10 ÷ 12	0,5	105

Feeding pressure: 1 bar - Condensate return 50% at T = 90°C - Feeding water pressure = 3 bar at 15°C

Standard-production equipment

- Exchange tower in carbon steel and internal components in stainless steel
- Storage tank in carbon steel, complete with steam diffuser, supporting seatings, regular pipe connections and manhole, complete with:
 - Thermo-physical Deaerator
 - Steam inlet reduction valve
 - Temperature regulator
 - Steam reduction manual gate valves
 - Steam reduction by-pass valve
 - Tower preheating valve
 - At the tower steam inlet check valve
 - Steam inlet check valve
 - Y shaped filter regulator steam inlet
 - Boiler feeding valve
 - Water inlet manual gate valve
 - Y shaped filter for water inlet
 - Water inlet check valve
 - Water regulation solenoid valve
 - On/Off level sensor
 - Vacuum breaker
 - Thermometer
 - Thermometer bulb holder
 - Visual level indicator
 - Pressure safety valve
 - Condensate discharger

INSTALLATION ACCESSORIES

DETE - Thermo-physical Deaerator

THERMOPHYSICAL DEAERATOR FOR HIGH PRESSURE STEAM GENERATORS

Construction according to the European Directive 97/23/CE, art. 3, par. 3

Technical Data

Model	Degassed water flow rate		Volume		Feeding water pressure	Design pressure	Degassed water temperature
	min	max	utile	totale			
DETE	kg/h	kg/h	m ³	m ³	bar	bar	°C
1000	300	1500	700	1000	10 ÷ 12	0,5	105
2000	1750	3000	1400	2000	10 ÷ 12	0,5	105
4000	4000	5000	2800	4000	10 ÷ 12	0,5	105
6000	6000	8000	4200	6000	10 ÷ 12	0,5	105
8000	10000	12000	5600	8000	10 ÷ 12	0,5	105
10000	-	15000	7000	10000	10 ÷ 12	0,5	105
16000	-	22000	11200	16000	10 ÷ 12	0,5	105

Feeding pressure: 10-12 bar - Condensate return 50% at T = 90°C - Feeding water pressure = 3 bar at 15°C

Standard-production equipment

- Exchange tower in carbon steel and internal components in stainless steel
- Storage tank in carbon steel, complete with steam diffuser, supporting seatings, regular pipe connections and manhole, complete with:
 - Thermo-physical Deaerator
 - Steam inlet reduction valve
 - Temperature regulator
 - Steam reduction manual gate valves
 - Steam reduction by-pass valve
 - Tower preheating valve
 - At the tower steam inlet check valve
 - Steam inlet check valve
 - Y shaped filter regulator steam inlet
 - Boiler feeding valve
 - Water inlet manual gate valve
 - Y shaped filter for water inlet
 - Water inlet check valve
 - Water regulation solenoid valve
 - On/Off level sensor
 - Vacuum breaker
 - Thermometer
 - Thermometer bulb holder
 - Visual level indicator
 - Pressure safety valve
 - Condensate discharger

INSTALLATION ACCESSORIES

DEAR – Atmospheric Deaerator

ATMOSPHERIC DEAERATOR FOR STEAM GENERATORS (in CARBON STEEL)

Construction according to the European Directive 97/23/CE, art. 3, par. 3

Technical Data

Model	Dearation capacity	Feeding water pressure	Design pressure	Deaerated water temperature
DEAR	kg/h	bar	bar	°C
500	500	10 ÷ 12	0,5	90
1000	1000	10 ÷ 12	0,5	90
1500	1500	10 ÷ 12	0,5	90
2000	2000	10 ÷ 12	0,5	90
2500	2500	10 ÷ 12	0,5	90
3000	3000	10 ÷ 12	0,5	90
4000	4000	10 ÷ 12	0,5	90
5000	5000	10 ÷ 12	0,5	90
8000	8000	10 ÷ 12	0,5	90
10000	10000	10 ÷ 12	0,5	90

Standard-production equipment

- Condensate collecting and deaerating tank in carbon steel
- ATMOSPHERIC DEAERATING GROUP complete with:
 - Thermometric system for temperature regulation
 - Steam injector(s)
 - Regulation valve
 - Vacuum breaking valve
 - Thermometric regulation system complete with stainless steel bulb holder
 - Condensate collecting and deaerating tank
 - Level indicator magnetically operated for local reading
 - Water reinstatement control group, with interception on condensate discharge and return
 - Y shaped filter
 - Two way valve, pneumatic piston operated, for On-Off control (modulating system on request)
 - Ball gate valve
 - Manual ball gate valve
 - Panel board

INSTALLATION ACCESSORIES

DEAR - Atmospheric Deaerator

ATMOSPHERIC DEAERATOR FOR STEAM GENERATORS (in STAINLESS STEEL)

Construction according to the European Directive 97/23/CE, art. 3, par. 3

Technical Data

Modello	Dearation capacity	Pressione alimentazione acqua	Pressione di bollo	Temperatura acqua degasata
DEAR	kg/h	bar	bar	°C
500	500	10 ÷ 12	0,5	90
1000	1000	10 ÷ 12	0,5	90
1500	1500	10 ÷ 12	0,5	90
2000	2000	10 ÷ 12	0,5	90
2500	2500	10 ÷ 12	0,5	90
3000	3000	10 ÷ 12	0,5	90
4000	4000	10 ÷ 12	0,5	90
5000	5000	10 ÷ 12	0,5	90
8000	8000	10 ÷ 12	0,5	90
10000	10000	10 ÷ 12	0,5	90

Standard-production equipment

- Condensate collecting and deaerating tank in stainless steel AISI 304
- ATMOSPHERIC DEAERATING GROUP complete with:
 - Thermometric system for temperature regulation
 - Steam injector(s)
 - Regulation valve
 - Vacuum breaking valve
 - Thermometric regulation system complete with stainless steel bulb holder
 - Condensate collecting and deaerating tank
 - Level indicator magnetically operated for local reading
 - Water reinstatement control group, with interception on condensate discharge and return
 - Y shaped filter
 - Two way valve, pneumatic piston operated, for On-Off control (modulating system on request)
 - Ball gate valve
 - Manual ball gate valve
 - Panel board

TERNOx

Three pass hot water boiler

Enbloc, horizontal, three pass, smoke pipe type, hot water boiler, with combustion chamber wet bottom. Sized to grant both, surface and combustion chamber low thermal loadings.

Low polluting emissions with the use of Low NOx burners.

Wide range composed of **10 models** with a nominal output **from 2500 kW up to 10500 kW**.

Standard maximum working pressure is 5 bar. On request 6 or 8 bar are also available.

CE certified according to European Directive 90/396/CE (GAD – Gas Appliances Directive)

Standard supplied complete with insulation, casing and panel board.

Standard-production equipment

- Casing in aluminium
- Rock wool insulation for burner blast tube
- Counter flanges, gaskets and bolts for flanged connections
- Pre-drilled burner plate according to burner type
- Two stage operation panel board

Optional equipment

- Casing in stainless steel
- Special panel board according to request
- Ladder and gangway

Technical Data

Model	Nominal Output	Nominal Input	Smoke diide press. losses	Water side press. losses*	Water content	Burner max blast tube diameter	Burner head min./ max. length	Dry weight (5 bar version)
	kW	kW	mbar	mbar	l	mm	mm	kg
2500	2500	2700	5,6	55	5020	330	250/480	5700
3000	3000	3240	5,5	72	5610	330	250/480	7110
3500	3500	3780	7,7	95	6332	330	250/480	7650
4000	4000	4320	5,4	130	7793	400	280/480	9250
4500	4500	4860	7	170	8561	400	280/480	10050
5000	5000	5400	8,2	180	8561	400	280/480	10200
5800	5800	6270	5,6	120	11984	500	370/550	13300
7000	7000	7560	8,4	150	13227	500	370/550	14200
8500	8500	9180	8,1	220	16952	550	420/600	19200
10500	10500	11340	8,7	180	19733	550	420/600	23000

*For a water flow rate corresponding to a $\Delta t = 15$ K

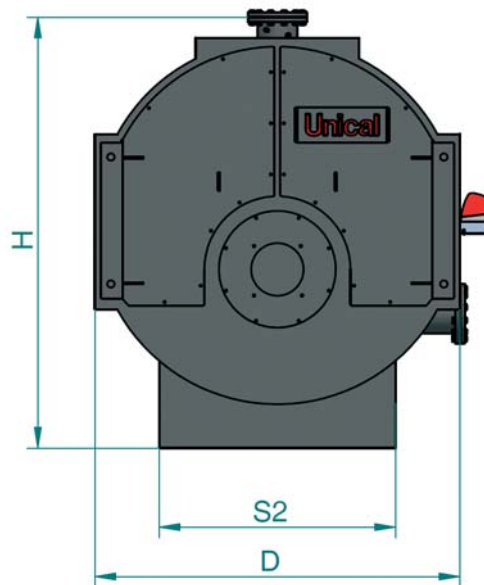
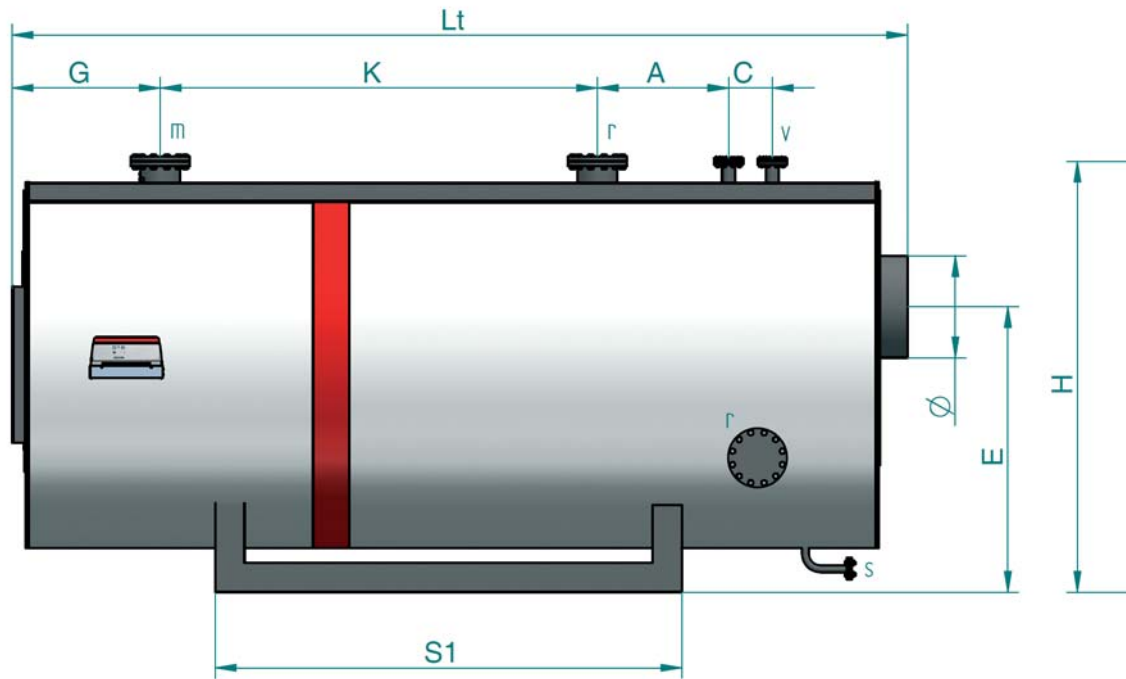

Dimensions

Model	D	H	Lt	E	G	K	A	C	J	F	B	S1	S2	m/r	v	s	ø
	Mm	mm	mm	mm	mm	mm	mm	mm	mm	mm	mm	mm	mm	DN	2 x DN	DN	mm
2500	1930	2330	4510	1530	830	1970	750	220	3700	690	960	2400	1250	200	2"	40	500
3000	2050	2450	4510	1650	830	1970	750	220	3700	750	995	2400	1310	200	2"	40	500
3500	2050	2460	4960	1650	830	2420	750	250	4150	750	995	2720	1310	200	65	40	500
4000	2260	2660	5100	1780	860	2450	750	250	4210	830	1070	2750	1500	200	65	40	600
4500	2260	2660	5550	1780	860	2800	800	300	4660	830	1070	3000	1500	200	80	40	600
5000	2260	2660	5550	1780	860	2800	800	300	4660	830	1070	3000	1500	200	80	40	600
5800	2500	2950	6070	1955	922	3000	900	300	5020	920	1225	3200	1620	250	80	40	700
7000	2500	2950	6570	1955	922	3450	900	350	5520	920	1225	3500	1620	250	100	40	700
8500	2750	3200	7020	2110	1022	3600	1000	350	5870	1000	1305	3700	1800	250	100	40	800
10500	2910	3360	7320	2210	1022	3900	1000	350	6170	1050	1335	4000	1900	300	100	40	900

Enbloc, horizontal, reversed flame, smoke pipe type, middle and high pressure overheated water boiler, with wet bottom combustion chamber, sized to grant both, surface and combustion chamber low thermal loadings.

Wide range composed of **14 models** with a nominal output **from 140 kW up to 2900 kW**.

Design and construction according to the Essential Safety Requirements of the European Directive 97/23/CE (PED – Pressure Equipment Directive)

■ FRONT DOOR

Fitted on hinges, with reversible opening. It is in welded steel sheet, with the inside completely insulated with refractory concrete. Complete with burner plate and flame sight glass

■ REAR SMOKE CHAMBER

Made of steel sheet and complete of horizontal smoke spigot for chimney connection and cleaning openings

■ BASEMENT

In steel profiles

■ THERMAL INSULATION

Made from a mineral wool mattress, externally protected by painted steel panels

■ DELIVERY

Is complete with panel board, safety and control devices

Max. working pressure: 4.9 bar (for SUHR' 5) – 9.8 bar (for SUHR'10)

Max. working temperature: 158.1 °C (for SUHR' 5) – 183.2 °C (for SUHR'10)

Available on request a version for M.W.P. = 11.76 bar (only for SUHR' 10 range)

Technical Data

Model	Nominal Output	Nomonal Input	Smoke side press. losses	Water side press losses*	Water Content	Dry wight (4,9 bar)
	kW	kW	mbar	mbar	l	kg
140	140	157	2,0	3,7	335	760
210	210	235	2,5	8	410	1080
270	268	300	3,0	13	410	1080
370	372	418	4,2	11	780	1540
465	465	523	4,5	17	780	1540
580	581,5	653	5,0	12	875	1675
700	700	784	6,0	18	964	2060
930	930	1046	6,5	20	1189	2350
1160	1163	1307	7,0	30	1485	2930
1400	1396	1568	7,0	24	1696	3500
1750	1745	1960	8,0	37	2455	4240
2050	2035	2287	8,2	30	2750	4790
2300	2325	2613	9,0	40	3100	5870
2900	2907	3267	9,5	45	4200	7000

*For a water flow rate corresponding to a $\Delta t = 15$ K

Standard-production equipment

- Casing in insulated steel panels
- Turbulators
- Spring actuated safety valve(s)
- Manual draining group
- N. 1 dial type thermometer
- N. 1 dial type manometer with 3 way cock for calibration purposes
- N. 2 working thermostats
- N. 1 manual reset safety thermostat
- N. 1 manual reset safety pressure switch

Optional equipment

- A 3rd working thermostat
- Pre-drilled burner plate according to burner type
- Max. working pressure of 11.76 bar (only for SUHR'10 range)
- Lever quick operated desludging valve
- Burner

Special versions for all models

SUHR' 24 hr

Equipped in order to obtain the certification for operation w/o continuous surveillance up to 24 hrs

SUHR' 72 hr

Equipped in order to obtain the certification for operation w/o continuous surveillance up to 72 hrs

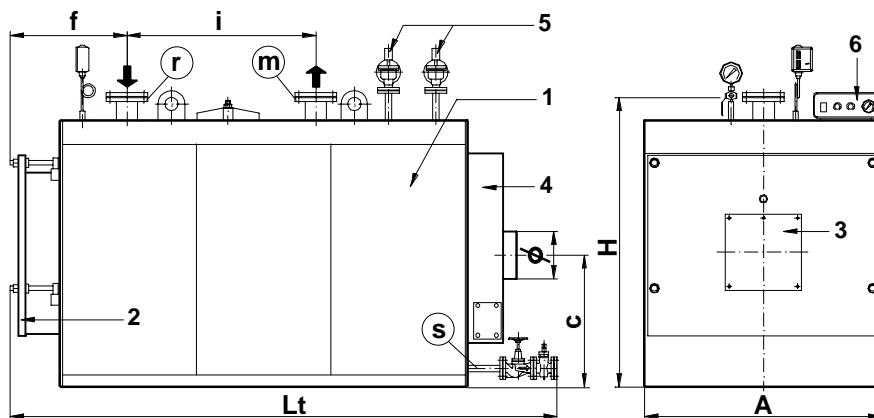

Dimensions

Model	A	H	Lt	c	f	i	r - m	s	Flue spigot Ø
	mm	mm	mm	mm	mm	mm	DN	DN	mm
140	950	1235	1550	580	375	700	65	25	220
210	950	1225	1970	580	425	950	65	25	220
270	950	1225	1970	580	425	950	65	25	220
370	1140	1430	2280	680	477	1060	80	25	250
465	1140	1430	2280	680	477	1060	80	25	250
580	1210	1510	2350	725	487	1100	100	25	250
700	1210	1510	2550	725	487	1360	100	25	250
930	1350	1670	2635	805	578	1200	125	25	350
1160	1350	1670	3135	805	578	1700	125	25	350
1400	1460	1770	3060	835	568	1600	150	40	400
1750	1640	1940	3400	950	570	1800	150	40	450
2050	1740	2050	3400	1008	685	1700	200	40	450
2300	1780	2080	3600	1020	695	1886	200	40	500
2900	1890	2190	4200	1075	720	2380	200	40	500

TRYSŪHR'

Three pass, overheated water boiler

Enbloc, horizontal, three pass, smoke pipe type, middle and high pressure overheated water boiler, with wet bottom combustion chamber, sized to grant both, surface and combustion chamber low thermal loadings.

Wide range composed of **12 models** with a nominal output **from 870 kW up to 10,000 kW**.

Design and construction according to the Essential Safety Requirements of the European Directive 97/23/CE (PED – Pressure Equipment Directive)

Supply complete with insulation, casing, panel board, control and safety devices

Max. working pressure: 9.8 bar (higher pressure upon request)

Max. working temperature: 183.2 °C (9.8 bar)

Technical Data

Model	Nominal Output	Nominal Input	Smoke side press. losses	Water content	Burner max blast tube diameter	Burner head min./ max. length	Dry weight (9,8 bar)
	<i>kW</i>	<i>kW</i>	<i>mbar</i>	<i>l</i>	<i>mm</i>	<i>mm</i>	<i>kg</i>
870	870	960	3,0	2800	According to burner manufacturer instructions	According to burner manufacturer instructions	4150
1160	1160	1280	5,6	2870			6100
1400	1395	1550	6,7	3600			6800
1800	1750	1940	5,4	3980			7400
2300	2300	2550	3,5	8250			9200
2900	2900	3220	6,0	9200			10600
3500	3500	3880	7,5	10840			14300
4650	4650	5160	7,0	11400			15000
5800	5800	6440	5,8	12520			17600
7000	7000	7740	10,0	14700			19200
8300	8300	9220	10,0	16800			24350
10000	10000	11100	11,0	19000			28400

Standard-production equipment

- Insulation + casing in aluminium
- Panel board for two stage operation
- N. 2 spring actuated safety valves
- Draining group with quick desludging valve
- N. 1 dial type thermometer
- N. 1 dial type manometer with 3 way cock for calibration purposes
- N. 1 manual reset safety pressure switch

Optional equipment

- A 3rd working thermostat
- Pre-drilled burner plate according to burner type
- Higher working pressure
- Ladder and gangway
- Smoke thermometer
- Recirculation pump with thermostat
- Burner

Special versions for all models

TRYSUHR' 24 hr

Equipped in order to obtain the certification for operation w/o continuous surveillance up to 24 hrs

TRYSUHR' 72 hr

Equipped in order to obtain the certification for operation w/o continuous surveillance up to 72 hrs

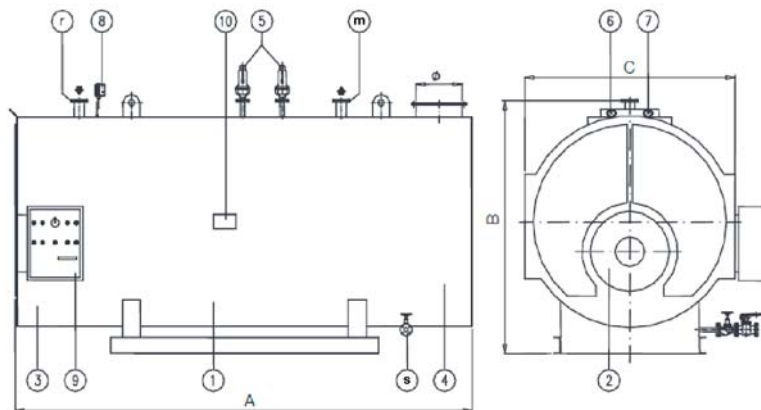

Dimensions

Model	A	B	C	m/r	s	ø
	mm	mm	mm	DN	DN	mm
870	3500	1800	1480	100	25	300
1160	3600	2150	1660	125	25	350
1400	3900	2150	1660	150	40	350
1800	3900	2340	1850	150	40	400
2300	4970	2650	2160	150	40	450
2900	5370	2650	2160	200	40	450
3500	5300	2900	2410	200	40	550
4650	5770	2990	2470	200	40	600
5800	6370	3000	2500	250	40	700
7000	6870	3000	2500	250	40	700
8300	7320	3210	2710	250	40	800
10000	7500	3590	2900	300	40	900

DĪATHER'

Diathermic oil boiler

Three pass, horizontal, mono or multi-coil diathermic oil boiler, with pressurized combustion, suitable for gas, oil and heavy oil burners, also Low NOx burners.

Wide range, composed of **14 models**, with nominal output **from 116 up to 5815 kW**.

■ COIL

with two concentric rings made of spiral "seamless steel tube" in contact each other in order to constitute two cylinders, with a refractory dry bottom

■ BOILER BOTTOM

Bolted type, insulated and equipped with cleaning door and flue spigot for chimney connection

■ FURNACE

Three pass type, accessible from the front

■ FRONT DOOR

Of wide dimensions in order to ease the service works, fitted on hinges, insulated with refractory concrete and equipped with burner plate and flame sight glass

■ EXTERNAL INSULATION

Made of two layers of high density rock wool

■ CASING

In aluminium

Technical Data

Model	Nominal Output	Nominal Input	Smoke side press. loss	Oil pump flow rate	ΔT	Pump manom. head	Pump power	Burner head max. dia.	Burner tube min./max. length	Dry weight
	kW	kW	mbar	m ³ /h	K	m.c.l.	kW	mm	mm	kg
120	116	134	1,5	6	35	45	3,0	150	150/200	530
230	232	267	2,0	10,6	40	49	5,5	180	190/250	780
350	348	401	2,5	15	42	48	5,5	180	220/300	1000
465	465	534	3,0	22	38	45	5,5	260	220/300	1520
700	697	802	3,4	30	42	45	7,5	260	220/300	1700
930	930	1069	3,5	42	40	40	7,5	270	220/300	2200
1160	1163	1337	3,8	50	42	46	11,0	270	220/300	2950
1500	1512	1738	4,0	69	40	42	11,0	310	220/300	3700
1900	1861	2139	4,2	81	42	50	15,0	310	220/300	4080
2300	2326	2673	4,5	101	42	49	15,0	340	220/300	5300
2900	2907	3342	4,5	126	42	60	30,0	380	250/300	7200
3500	3489	4010	5,0	159	40	56	30,0	380	250/300	8000
4650	4652	5347	6,0	202	42	58	37,0	400	250/300	12250
5800	5815	6684	7,0	252	42	58	45,0	400	250/300	14560

DĪATHER'

Diathermic oil boiler

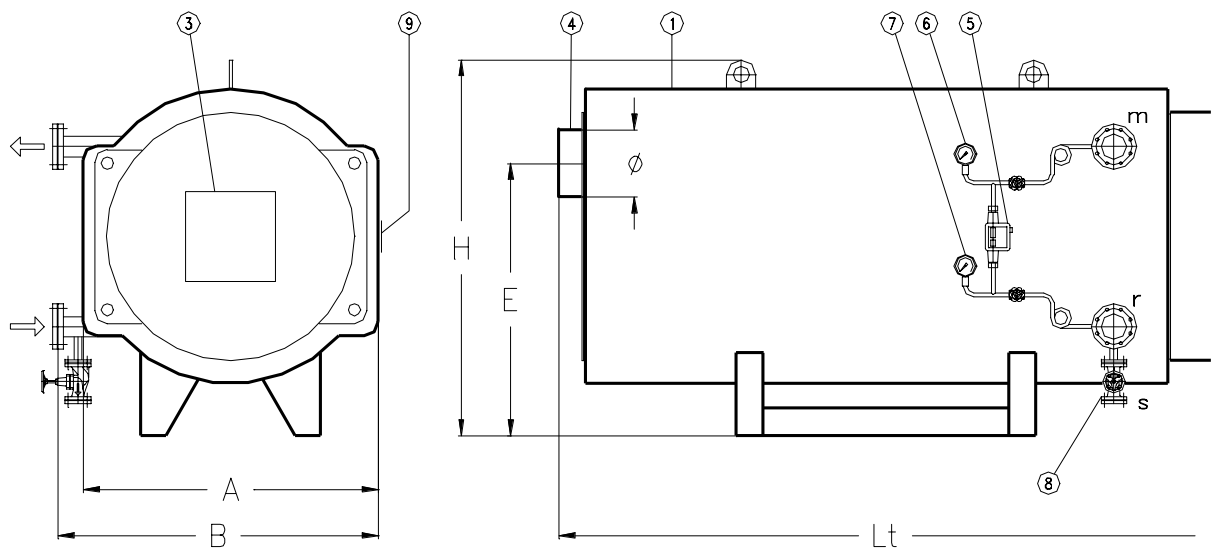

Dimensions

Model	A	B	H	E	Lt	m/r	s	∅
	mm	mm	mm	mm	mm	DN	DN	mm
120	890	1045	1200	750	1260	32	20	200
230	1000	1150	1330	850	1650	40	20	250
350	1000	1150	1330	850	2100	50	25	250
465	1210	1335	1570	1070	2320	65	25	300
700	1210	1295	1570	1070	2570	65	25	300
930	1310	1375	1680	1150	2970	80	25	350
1160	1500	1590	1910	1370	3170	100	25	350
1500	1630	1685	2040	1480	3570	100	25	400
1900	1630	1685	2040	1480	3920	125	25	400
2300	1800	1800	2210	1620	4270	125	25	450
2900	2150	2150	2560	1950	4500	150	32	500
3500	2150	2150	2560	1950	5100	150	32	500
4650	2460	2600	2910	2270	6050	200	40	600
5800	2660	2800	3160	2450	6450	200	40	700

